

Wi-SUN Module

Wireless communication module for Wi-SUN FAN

BP35C5

General Description

BP35C5 is a Wi-SUN FAN compatible wireless communication module.

Features

- RF designed
- Antenna terminal 50 Ω impedance adjusted
- Transmission output power adjusted
- Built-in Wi-SUN FAN software stack

Package



W (Typ.) x D (Typ.) x H (Typ.)
19.0 mm x 15.0 mm x 2.6 mm

Major Performance

Parameter	Description
Radio standards	Compliant with ARIB STD-T108, FCC Part 15C
Radio frequency	920 MHz band
Modulation method	Binary GFSK
Data rate	ARIB STD-T108 : 50 kbps, 100 kbps, 150 kbps, 300 kbps FCC Part 15C : 50 kbps, 150 kbps, 300 kbps
Transmission power	20 mW, 10 mW, 1 mW
Receiving sensitivity	-105 dBm (TYP.) (50 kbps, BER<0.1%) -98 dBm (TYP.) (150 kbps, BER<0.1%)
Frequency tolerance	±20 ppm or less
Current consumption (VDD=3.3 V, Data rate=50 kbps)	40 mA (Typ.) [Transmission: 20 mW output] 20 mA (Typ.) [Reception]
Host interface	UART (115,200 bps), GPIO

Block Diagram

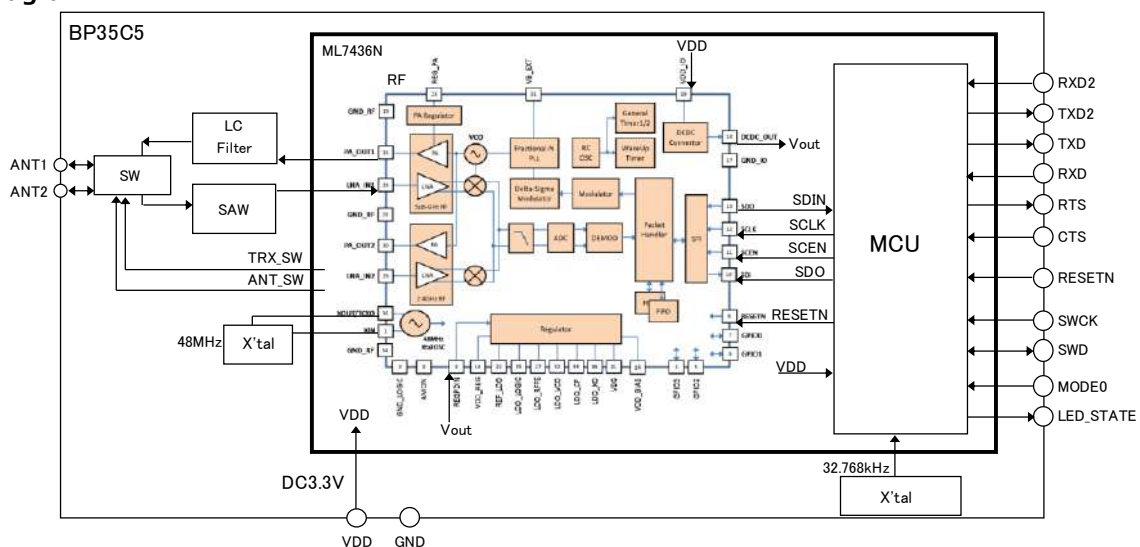

Fig. 1. Block Diagram

1. Absolute Maximum Ratings

No.	Parameter	Symbol	Rating	Unit	Condition
1	Supply voltage	VDD	-0.3 to +3.9	V	DC
2	Digital input voltage	V _{DIN}	-0.3 to VDD+0.3	V	
3	Digital output voltage	V _{DO}	-0.3 to VDD+0.3	V	
4	Digital output current	I _{DO}	-8 to+8	mA	
5	RF Input power	PIN	0	dBm	
6	Operating temperature range	Topr	-30 to 85	°C	
7	Storage temperature range	Tstg	-40 to 85	°C	

(Note) The absolute maximum ratings represent values that shall not be exceeded for even an instant on all operating or testing conditions.

Design systems with a margin for the ratings listed above.

2. Recommended Operating Conditions

No.	Parameter	Symbol	Specification			Unit	Condition
			Min.	Typ.	Max.		
1	Supply voltage	VDD	2.6	3.3	3.6	V	
2	Operating temperature range	Ta	-30	25	85	°C	

3. Electrical Characteristics

Input current characteristics

(Ta=25 °C, VDD=3.3 V)

No.	Parameter	Condition	Specification			Unit
			Min.	Typ.	Max.	
1	Current consumption (Data rate: 50 kbps)	Transmission state (set to 20 mW)	-	40	47	mA
		Transmission state (set to 10 mW)	-	36	44	
		Transmission state (set to 1 mW)	-	27	34	
2		Reception state	-	20	26	mA

Measurement was made with the terminating end of 50 ohm measuring instrument connected with the antenna connector terminal of the module using RF cable.

RF characteristics

Measurement conditions: Ta=25 °C and VDD=3.3 V

Modulation rate: 50 kbps, 150 kbps

Modulation method: Binary GFSK

Measurement made at the antenna connector terminal of the module

Transmission characteristics

(Ta=25 °C, VDD=3.3 V)

No.	Parameter	Condition	Specification			Unit
			Min.	Typ.	Max.	
1	Transmission output power	20 mW mode	11.6	12.8	13.8	dBm
		10 mW mode	8.9	10.7	11.6	dBm
		1 mW mode	0.4	1.8	3.6	dBm
2	Occupied bandwidth	n=1 (50 kbps)	-	88	200	kHz
		n=2 (150 kbps) *	-	166	400	kHz
3	Adjacent channel leakage power [ACPR]	20 mW mode ± 1 channel Bandwidth: 200 kHz	-	-30	-15	dBm
4	Frequency shift [Fdev] *	50 kbps	-	25	-	kHz
		150 kbps		37.5		kHz
5	Frequency tolerance	CW wave	-20	-	20	ppm

Be noted that the parameter marked with "*" represents a design guaranteed value.

Transmission characteristics (continued)

(Ta=25 °C, VDD=3.3 V)

No.	Parameter	Condition	Specification			Unit
			Min.	Typ.	Max.	
6	Spurious emission levels for transmission (in 20 mW mode)	100 kHz bandwidth below 710 MHz	-	-	-36	dBm
7		1 MHz bandwidth between 710 MHz and 900 MHz	-	-	-55	dBm
8		100 kHz bandwidth between 900 MHz and 915 MHz	-	-	-55	dBm
9		100 kHz bandwidth between 915 MHz and 930 MHz (except levels detuned by 400 kHz or less from the center of radio channels (n=2); provided that levels ranging from 920.5 MHz to 922.3 MHz and detuned by 300 kHz or less shall be excluded)	-	-	-36	dBm
10		100 kHz bandwidth between 930 MHz and 1 GHz	-	-	-55	dBm
11		1 MHz bandwidth between 1 GHz and 1.215 GHz	-	-	-45	dBm
12		1 MHz bandwidth between 1.215 GHz and 2.5 GHz (second harmonic)	-	-	-30	dBm
13		1 MHz bandwidth over 2.5 GHz (over third harmonic)			-44.3	dBm

Reception characteristics

(Ta=25 °C, VDD=3.3 V)

No.	Parameter	Condition	Specification			Unit
			Min.	Typ.	Max.	
14	Minimum receiving sensitivity *	50 kbps, BER<0.1 %,	-	-105	-95	dBm
		150 kbps, BER<0.1 %,		-98	-88	
15	Maximum receiving input level *	-	0	-	dBm	
16	Minimum power detection (ED value) level *	-	-	-95	dBm	
17	Power detection range *	Dynamic range	-	60	-	dB

Be noted that the parameter marked with "*" represents a design guaranteed value.

Reception characteristics (continued)

(Ta=25 °C, VDD=3.3 V)

No.	Parameter	Condition	Specification			Unit
			Min.	Typ.	Max.	
18	Subsidiary emission levels	100 kHz bandwidth below 710 MHz *	-	-	-54	dBm
19		1 MHz bandwidth between 710 MHz and 900 MHz *	-	-	-55	dBm
20		100 kHz bandwidth between 900 MHz and 915 MHz *	-	-	-55	dBm
21		100 kHz bandwidth between 915 MHz and 930 MHz *	-	-	-54	dBm
22		100 kHz bandwidth between 930 MHz and 1 GHz *	-	-	-55	dBm
23		1 MHz bandwidth over 1 GHz *	-	-	-47	dBm

Be noted that the parameter marked with "*" represents a design guaranteed value.

4. Interface Characteristics

Terminal characteristics (design guarantee values)

(Ta=-30 to +85 °C, VDD=2.6 V to 3.6 V)

No.	Parameter	Symbol	Condition	Specification			Unit
				MIN.	TYP.	MAX.	
1	High-level input voltage	VIH1	(*1)	VDDx0.75	–	VDD	V
2	Low-level input voltage	VIL1	(*1)	0	–	VDDx0.18	V
3	High-level output voltage	VOH	3.0 V ≤ VDD ≤ 3.6 V IOH = -3.5 mA (*2)	VDDx0.75	–	VDD	V
			2.6 V ≤ VDD ≤ 3.0 V IOH = -1.25 mA (*2)				
4	Low-level output voltage	VOL	3.0 V ≤ VDD ≤ 3.6 V IOL = 3.5 mA (*2)	0	–	0.55	V
			2.6 V ≤ VDD ≤ 3.0 V IOL = 1.25 mA (*2)	0	–	0.45	
5	Input capacitance	CIN	Input terminal (RESETN)	–	6	–	pF
		CIO	Input output (*1), (*2)	–	9	–	
		CAI	Analog input (*3)	–	20	–	

(*1) Pin shown as "I" in the "I/O" column in "Pin Description" table.

(*2) Pin shown as "O" in the "I/O" column in "Pin Description" table.

(*3) Pin shown as "IA" in the "I/O" column in "Pin Description" table.

* Hereinafter, for digital input / output voltage, high level is referred to "High", and low level is referred to "Low".

UART specification

Parameter	Specification
Baud rate	115,200 bps
Data width	8 bits
Parity	Not provided
Stop bit	1 bit
HW flow control (*1)	Disabled (Default)

It is able to check and change the setting via commands. For details, refer to the software specification.

(*1) You should verify and determine whether to disable or enable the HW flow control.

Reset characteristics (design guarantee value)

Make sure that this Product can be reset by controlling Pin No.4 (RESETN) from a host MCU and so on.

($T_a = -30\text{ }^{\circ}\text{C}$ to $+85\text{ }^{\circ}\text{C}$, $V_{DD} = 2.6\text{ V}$ to 3.6 V)

Parameter	Symbol	Condition	Specification			Unit
			Min.	Typ.	Max.	
RESETN pulse period (When starting from $V_{DD} = 0\text{ V}$) (*1)	TRPW	-	200	-	-	ns
RESETN pulse period 2 (When starting from $V_{DD} \neq 0\text{ V}$) (*2)	TRPW2	$V_{DD} > 2.6\text{ V}$	1	-	-	ms

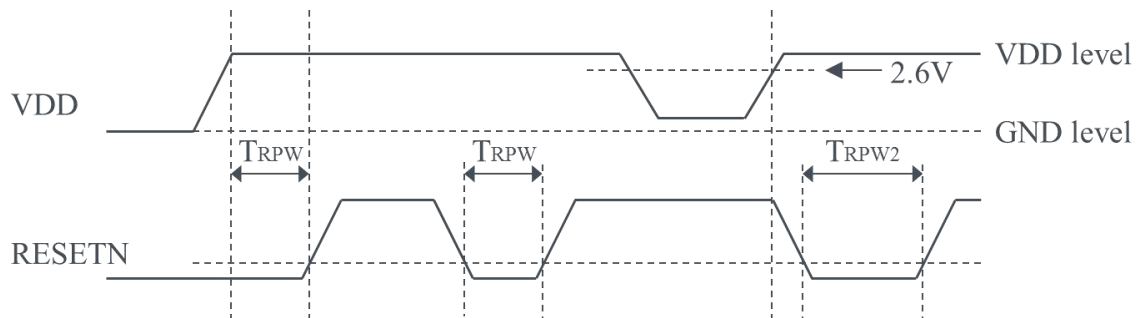

(*1) Input High level signal, following an assert duration (longer than TRPW), to RESETN after VDD completely rising for start-up.

Input a pulse to RESETN after VDD completely rising and in stable state, for reset after start-up.

(*2) Input a pulse to RESETN after VDD completely rising for start-up from $V_{DD} \neq 0$.

In case of the voltage applied to RESETN and VDD simultaneously rising, input a pulse (longer than TRPW) to RESETN after VDD completely rising for start-up.

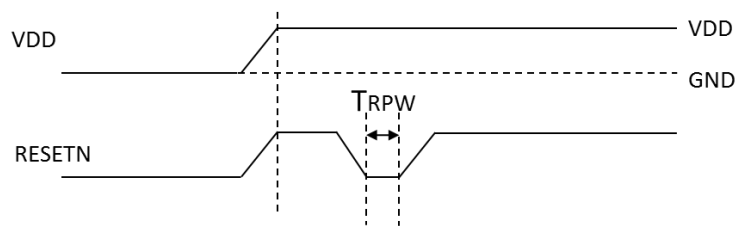

Power ON characteristics (design guarantee value)

(Ta=-30 °C to +85 °C, VDD=2.6 V to 3.6 V)

Parameter	Symbol	Condition	Specification			Unit
			Min.	Typ.	Max.	
Power ON time	TPWON	Power ON	-	-	5	ms

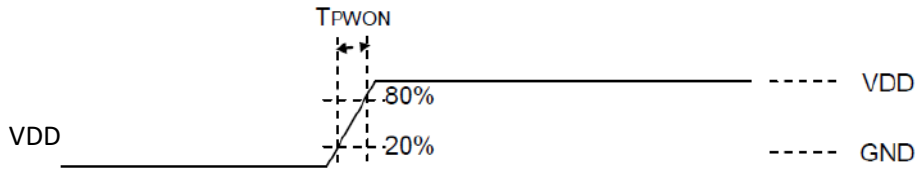

5. Channel Setting

For Japan region (ARIB STD-T108)

Region	Japan	Japan	Japan	Japan
Data Rate	50 kbps	100 kbps	150 kbps	300 kbps
n unit radio channel	1	2	2	3
Modulation Index	1	1	0.5	0.5
Channel space	200 kHz	200 kHz	200 kHz	200 kHz
Frequency Deviation	25.0 kHz	50.0 kHz	37.5 kHz	75.0 kHz

Channel Number	Center Frequency [kHz]	Center Frequency [kHz]	Center Frequency [kHz]	Center Frequency [kHz]
24	920.6	920.7	920.7	920.8
25	920.8	920.9	920.9	921.0
26	921.0	921.1	921.1	921.2
27	921.2	921.3	921.3	921.4
28	921.4	921.5	921.5	921.6
29	921.6	921.7	921.7	921.8
30	921.8	921.9	921.9	922.0
31	922.0	922.1	922.1	922.2
32	922.2	922.3	922.3	922.4
33	922.4	922.5	922.5	922.6
34	922.6	922.7	922.7	922.8
35	922.8	922.9	922.9	923.0
36	923.0	923.1	923.1	923.2
37	923.2	923.3	923.3	923.4
38	923.4	923.5	923.5	923.6
39	923.6	923.7	923.7	923.8
40	923.8	923.9	923.9	924.0
41	924.0	924.1	924.1	924.2
42	924.2	924.3	924.3	924.4
43	924.4	924.5	924.5	924.6
44	924.6	924.7	924.7	924.8
45	924.8	924.9	924.9	925.0
46	925.0	925.1	925.1	925.2
47	925.2	925.3	925.3	925.4
48	925.4	925.5	925.5	925.6
49	925.6	925.7	925.7	925.8
50	925.8	925.9	925.9	926.0
51	926.0	926.1	926.1	926.2
52	926.2	926.3	926.3	926.4
53	926.4	926.5	926.5	926.6
54	926.6	926.7	926.7	926.8
55	926.8	926.9	926.9	927.0
56	927.0	927.1	927.1	927.2
57	927.2	927.3	927.3	927.4
58	927.4	927.5	927.5	927.6
59	927.6	927.7	927.7	927.8
60	927.8	927.9	927.9	-
61	928.0	-	-	-

For United States region (FCC Part 15C) (1/4)

Region	US	US	US
Data Rate	50 kbps	150 kbps	300 kbps
Modulation Index	1	0.5	0.5
Channel space	200 kHz	400 kHz	600 kHz
Frequency Deviation	25.0 kHz	37.5 kHz	75.0 kHz

Channel Number	Center Frequency [kHz]	Center Frequency [kHz]	Center Frequency [kHz]
0	902.2	902.4	902.6
1	902.4	902.8	903.2
2	902.6	903.2	903.8
3	902.8	903.6	904.4
4	903.0	904.0	905.0
5	903.2	904.4	905.6
6	903.4	904.8	906.2
7	903.6	905.2	906.8
8	903.8	905.6	907.4
9	904.0	906.0	908.0
10	904.2	906.4	908.6
11	904.4	906.8	909.2
12	904.6	907.2	909.8
13	904.8	907.6	910.4
14	905.0	908.0	911.0
15	905.2	908.4	911.6
16	905.4	908.8	912.2
17	905.6	909.2	912.8
18	905.8	909.6	913.4
19	906.0	910.0	914.0
20	906.2	910.4	914.6
21	906.4	910.8	915.2
22	906.6	911.2	915.8
23	906.8	911.6	916.4
24	907.0	912.0	917.0
25	907.2	912.4	917.6
26	907.4	912.8	918.2
27	907.6	913.2	918.8
28	907.8	913.6	919.4
29	908.0	914.0	920.0
30	908.2	914.4	920.6
31	908.4	914.8	921.2
32	908.6	915.2	921.8
33	908.8	915.6	922.4
34	909.0	916.0	923.0
35	909.2	916.4	923.6
36	909.4	916.8	924.2
37	909.6	917.2	924.8

For United States region (FCC Part 15C) (2/4)

Region	US	US	US
Data Rate	50 kbps	150 kbps	300 kbps
Modulation Index	1	0.5	0.5
Channel space	200 kHz	400 kHz	600 kHz
Frequency Deviation	25.0 kHz	37.5 kHz	75.0 kHz

38	909.8	917.6	925.4
39	910.0	918.0	926.0
40	910.2	918.4	926.6
41	910.4	918.8	927.2
42	910.6	919.2	-
43	910.8	919.6	-
44	911.0	920.0	-
45	911.2	920.4	-
46	911.4	920.8	-
47	911.6	921.2	-
48	911.8	921.6	-
49	912.0	922.0	-
50	912.2	922.4	-
51	912.4	922.8	-
52	912.6	923.2	-
53	912.8	923.6	-
54	913.0	924.0	-
55	913.2	924.4	-
56	913.4	924.8	-
57	913.6	925.2	-
58	913.8	925.6	-
59	914.0	926.0	-
60	914.2	926.4	-
61	914.4	926.8	-
62	914.6	927.2	-
63	914.8	927.6	-
64	915.0	-	-
65	915.2	-	-
66	915.4	-	-
67	915.6	-	-
68	915.8	-	-
69	916.0	-	-
70	916.2	-	-
71	916.4	-	-
72	916.6	-	-
73	916.8	-	-
74	917.0	-	-
75	917.2	-	-
76	917.4	-	-
77	917.6	-	-

For United States region (FCC Part 15C) (3/4)

Region	US	US	US
Data Rate	50 kbps	150 kbps	300 kbps
Modulation Index	1	0.5	0.5
Channel space	200 kHz	400 kHz	600 kHz
Frequency Deviation	25.0 kHz	37.5 kHz	75.0 kHz

78	917.8	-	-
79	918.0	-	-
80	918.2	-	-
81	918.4	-	-
82	918.6	-	-
83	918.8	-	-
84	919.0	-	-
85	919.2	-	-
86	919.4	-	-
87	919.6	-	-
88	919.8	-	-
89	920.0	-	-
90	920.2	-	-
91	920.4	-	-
92	920.6	-	-
93	920.8	-	-
94	921.0	-	-
95	921.2	-	-
96	921.4	-	-
97	921.6	-	-
98	921.8	-	-
99	922.0	-	-
100	922.2	-	-
101	922.4	-	-
102	922.6	-	-
103	922.8	-	-
104	923.0	-	-
105	923.2	-	-
106	923.4	-	-
107	923.6	-	-
108	923.8	-	-
109	924.0	-	-
110	924.2	-	-
111	924.4	-	-
112	924.6	-	-
113	924.8	-	-
114	925.0	-	-
115	925.2	-	-
116	925.4	-	-
117	925.6	-	-

For United States region (FCC Part 15C) (4/4)

Region	US	US	US
Data Rate	50 kbps	150 kbps	300 kbps
Modulation Index	1	0.5	0.5
Channel space	200 kHz	400 kHz	600 kHz
Frequency Deviation	25.0 kHz	37.5 kHz	75.0 kHz

118	925.8	-	-
119	926.0	-	-
120	926.2	-	-
121	926.4	-	-
122	926.6	-	-
123	926.8	-	-
124	927.0	-	-
125	927.2	-	-
126	927.4	-	-
127	927.6	-	-
128	927.8	-	-

6. Setting of Communication Time Limit and Carrier Sensing Time

This Product has acquired the Technical Regulations Conformity Certification with the settings listed in the table below. The Products is not allowed to be used with any setting outside the setting range listed below.

Unit Channel Number	Data rate setting (Number of channels to use at a time)	Carrier sensing time	Transmission time limit	Pause time	Total of transmission time per hour
33-61 (JP)	50 kbps (n=1) 100 kbps (n=2) 150 kbps (n=2) 300 kbps (n=3)	128 μ s or more (Sensing at all times)	200 ms or less per transmission	2 ms or more	360 s or less With channel hopping; 720 s or less

Unit Channel Number	Data rate setting	Carrier sensing time	Transmission time limit	Pause time	Total of transmission time per hour
0-128 (US)	50 kbps 150 kbps 300 kbps 600 kbps	128 μ s or more (Sensing at all times)	400 ms or less per transmission	2 ms or more	-

7. List of Pins

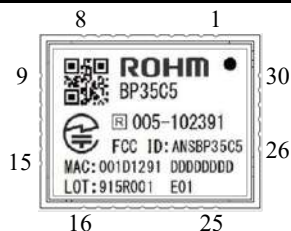

Pin No.	Pin Name	I/O	Attribute /Value at reset	Function
1	NC	-	-	Non connect (Open)
2	MODE0	I	I/-	Mode (GND at default)
3	GPIOB7/TXD2	I/O	oZ/-	Reserve (Open or Pull down)
				UART2_TXD (*4)
4	RESETN	I _S	I/-	Reset
5	SWCK	I/O	I/-	Debug clock (Pull down)
6	SWD	I/O	I/-	Debug data (Pull down)
7	GND	-	-	Ground
8	VDD	-	-	Power supply
9	GPIOB1/FTM	I/O	oZ/-	Reserve (Open)
10	GPIOB2	I/O	oZ/-	Reserve (Open)
11	GND	-	-	Ground
12	GPIOD0/RTS	I/O	oZ/-	Reserve (Open) (*1)
		O		UART_RTS (*2)
13	GPIOD1/CTS	I/O	oZ/-	Reserve (Open) (*1)
		I		UART_CTS (*2)
14	TXD	O	oZ/-	UART_TXD (data output)
15	RXD	I	oZ/-	UART_RXD (data input)
16	GPIOC0/RXD2	I/O	oZ/-	Reserve (Open)
		I		UART2_RXD (*4)
17	ADC2	I _A	I/-	Reserve (Open)
18	GPIOA0/SDA	I/O	oZ/-	Reserve (Open or LED etc.) (*3)
19	GPIOA1/SCL	I/O	oZ/-	Reserve (Open)
20	SPI_MISO	I/O	oZ/-	Reserve (Open)
21	SPI_SSN	I/O	oZ/-	Reserve (Open)
22	SPI_MOSI	I/O	oZ/-	Reserve (Open)
23	SPI_SCLK	I/O	oZ/-	Reserve (Open)
24	GND	-	-	Ground
25	NC	-	-	Non connect (Open)
26	GND	-	-	Ground
27	ANT1	RF I/O	-	Antenna 1
28	GND	-	-	Ground
29	ANT2	RF I/O	-	Antenna 2
30	GND	-	-	Ground

*I/O definition - I_A: Analog input, I: Digital input, O: Digital output,

I_S: Schmitt trigger input, oZ: High-impedance output, RF I/O: RF input and output

(*1) When HW flow control is disabled (Default)

(*2) When HW flow control is enabled

(*3) When status indicator is enabled (Default): Broad cast transmitting: High output

(*4) When UART2 is enabled

8. Reference Peripheral Circuit Diagrams

Border Router (for small network) / Router / Leaf mode (UART : 1 port)

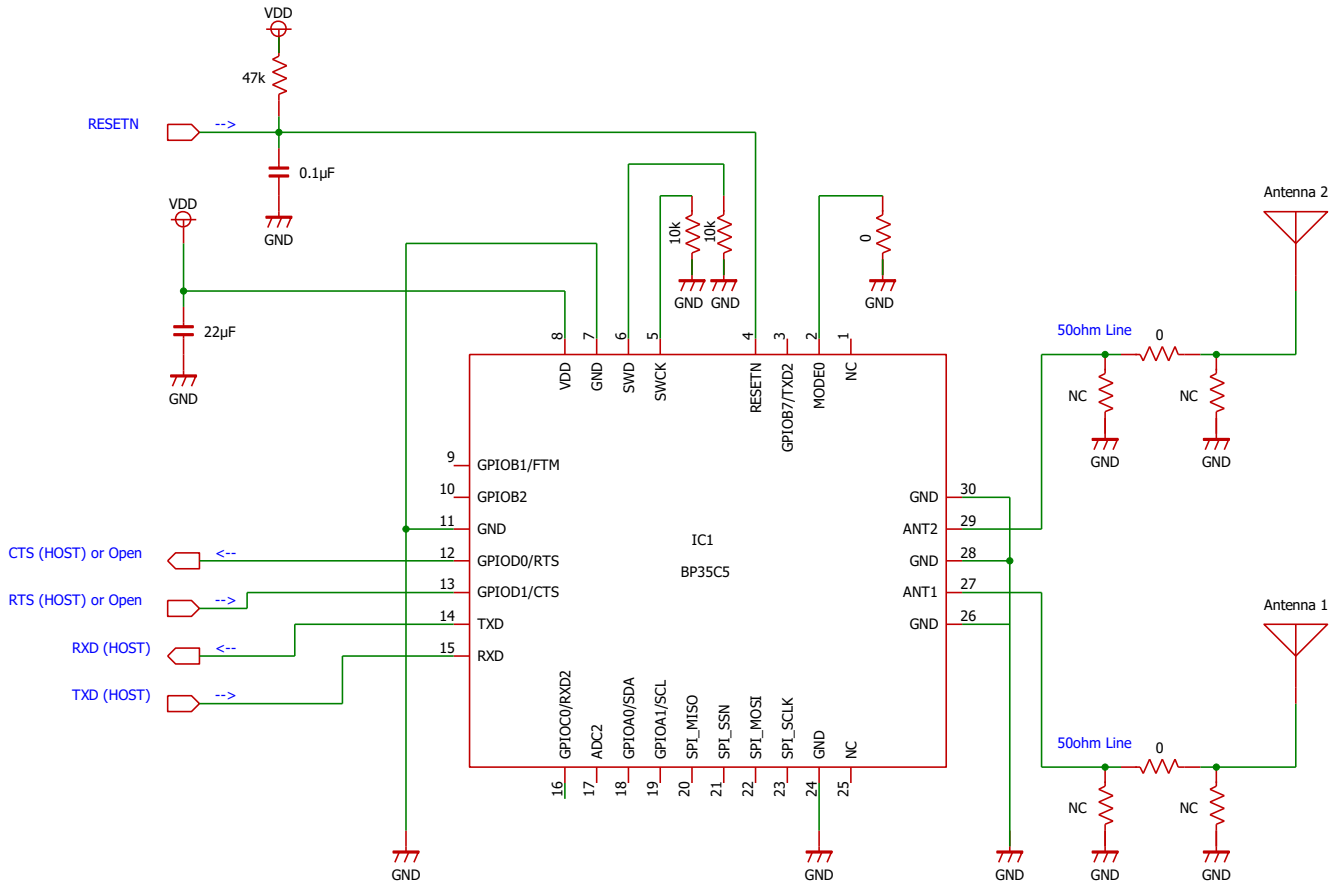

Fig. 2.1. Reference Peripheral Circuit Diagrams

Border Router (for large network) (UART : 2 ports)

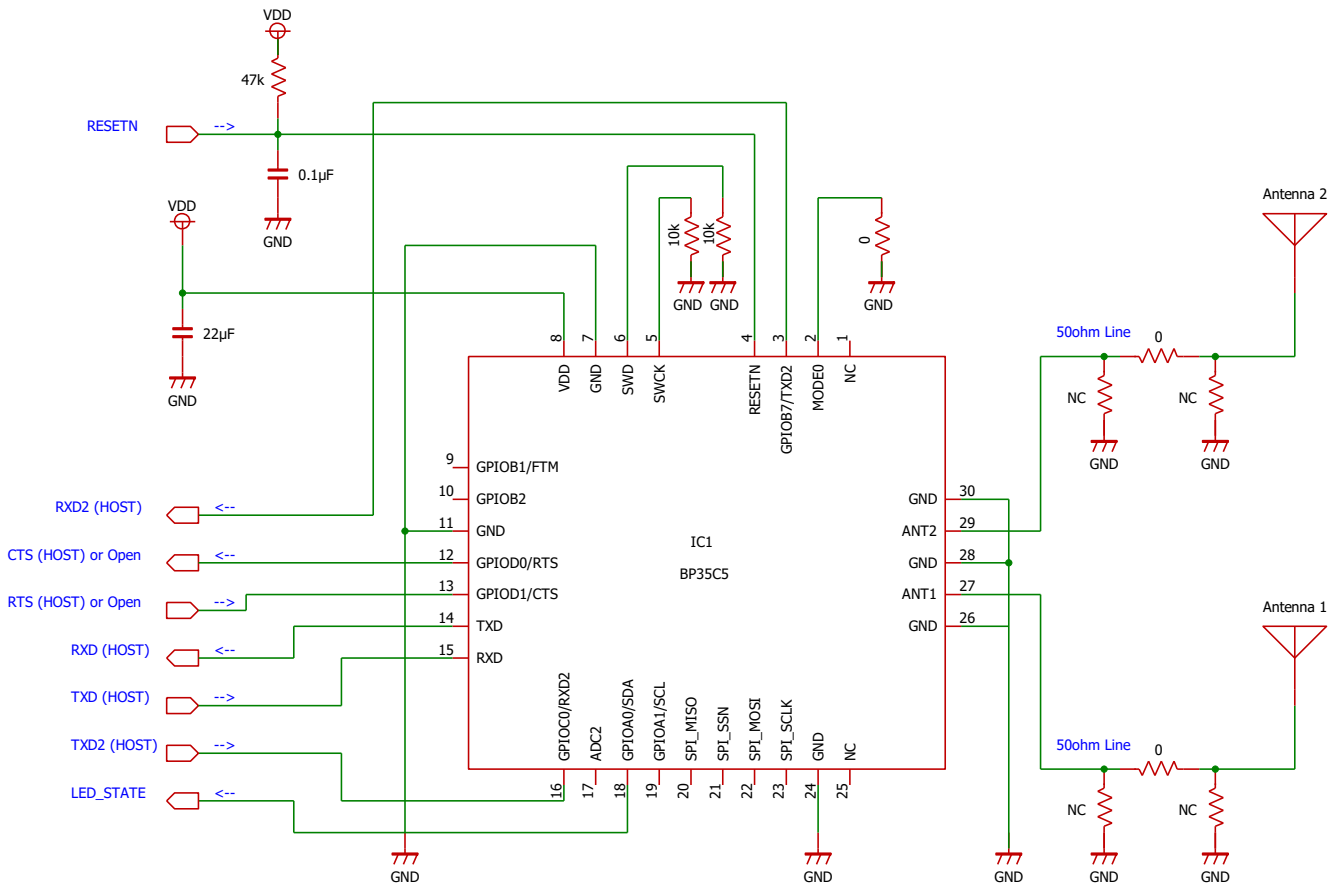

Fig. 2.2. Reference Peripheral Circuit Diagrams

9. Outline Dimensions



Fig. 3. Outline Dimensions Diagram

*Any defects in the appearance other than scratches and dents harmful to the practical use of this Product are overlooked.

10. Product Marking and Labeling Specification

The following items are indicated on the product.

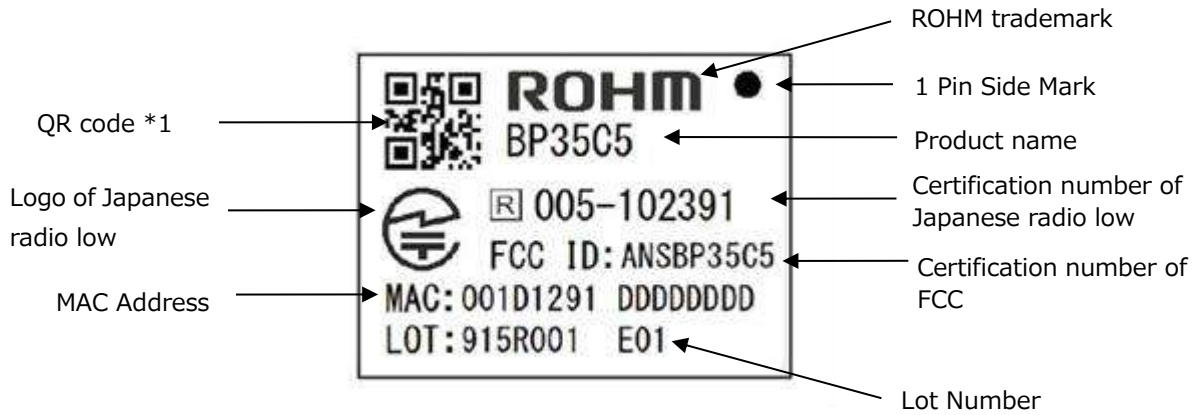



Fig. 4. Marking Specification

- *1 QR code has a product serial number as information.
The design of marking is subject to change without prior notice.

Marking information

ROHM	:	ROHM Trademark
BP35C5	:	Product name
915 * ▲▲▲	:	Manufacturing Lot Number (Example) 915*▲▲▲→ 2019_15 th week_*▲▲▲ (*: Secret serial number) (▲▲▲: Secret serial number)
 005-102391	:	Certification number of Japanese radio low
	:	Logo of Japanese radio low
FCC ID: ANSBP35C5	:	Certification number of FCC
001D12*****	:	MAC Address 001D12 (OUI (Vendor ID) : ROHM)

11. Recommended Land Pattern

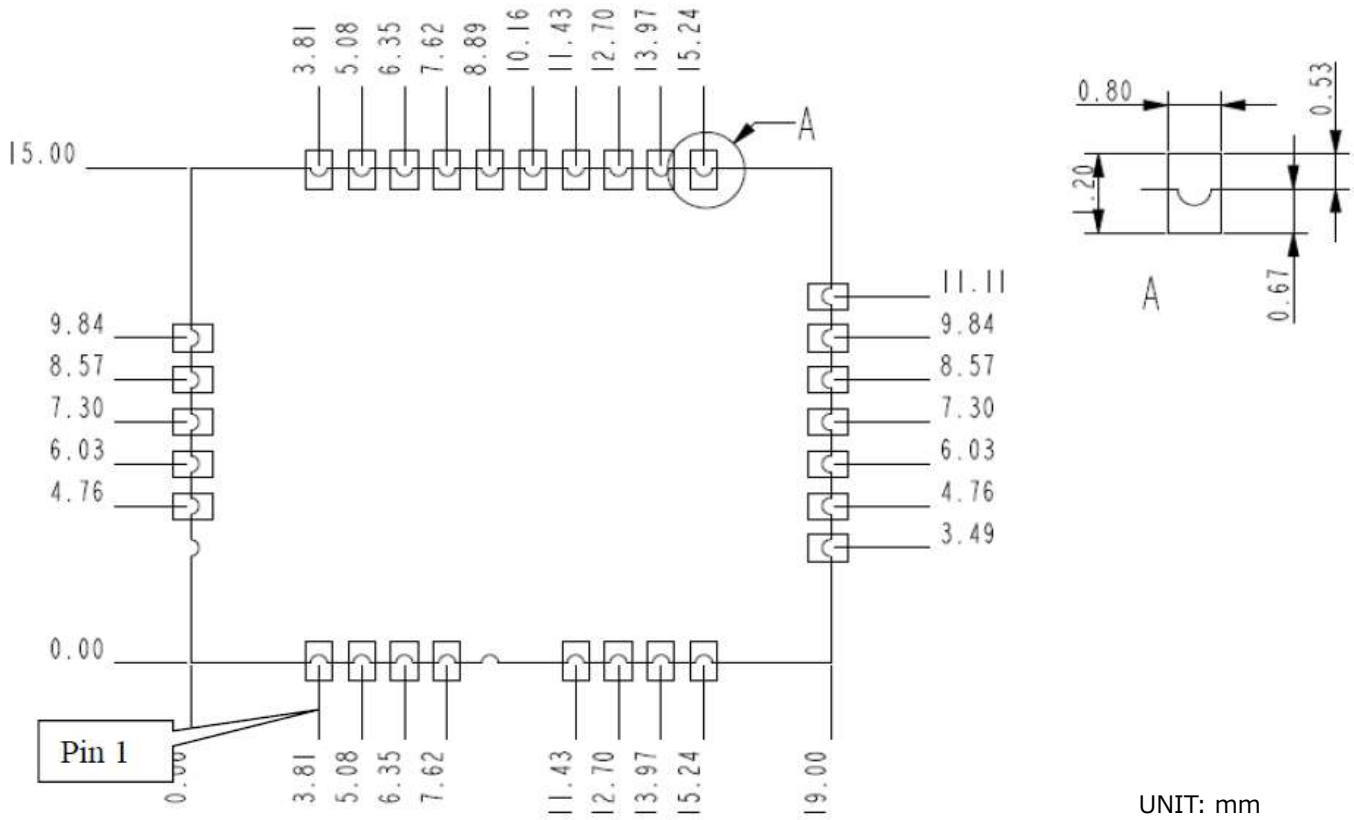

Fig.5. Recommended Land Pattern

Caution: There are patterning on the soldering surface (bottom side).

Please be sure not to wire (including GND) on the part of PCB under the module except land pattern.

12. Internal Structure and Material

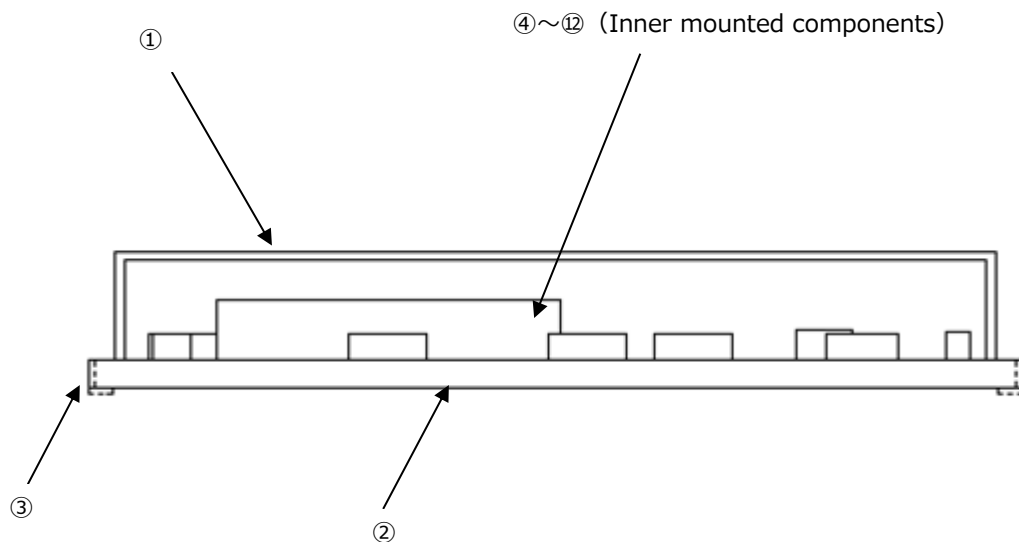

Fig.6 Internal structure diagram

No.	Name	Material
①	Shield case	Cu/Ni/Zn
②	PCB	FR-4
③	Terminal (*)	Cu/Ni/Au
④	IC (RF+MCU)	Si/Au/Sn/Ag/Cu/Epoxy resin/Silica
⑤	Crystal oscillator	Silica crystalline/Fe/Ni/Co/Au/Cr/Ag/Ceramic
⑥	Crystal oscillator	Silica crystalline/Fe/Ni/Co/Au/Cr/Sn/Mo/Ceramic
⑦	IC (RF Switch)	Si/Au/Sn/Ag/Cu/Epoxy resin/Silica
⑧	SAW Filter	LT/Al ₂ O ₃ /Au/Al/Epoxy resin/Silica
⑨	Ceramic capacitors	Ceramic/Cu/Ni/Sn/Silica
⑩	RF Inductors (Film)	Ceramic/Ag/Ni/Sn/Silica
⑪	RF Inductors (Wire wound)	Ceramic/Cu/Polyester imide/Ag/Ni/Sn/Silica/Epoxy resin/Talc
⑫	Inductor for power circuit	Ferrite/Cu/Polyester imide/Ag/Ni/Sn/Epoxy resin/Fe/Alloy

(*) Metal-surface treatment of terminal

Type of coat	Thickness
Foundation of nickel	2.997 μm (Min.)
Gold	0.051 μm to 0.127 μm

*It is a reference dimension, not a guaranteed value.

13. Recommended Reflow Condition

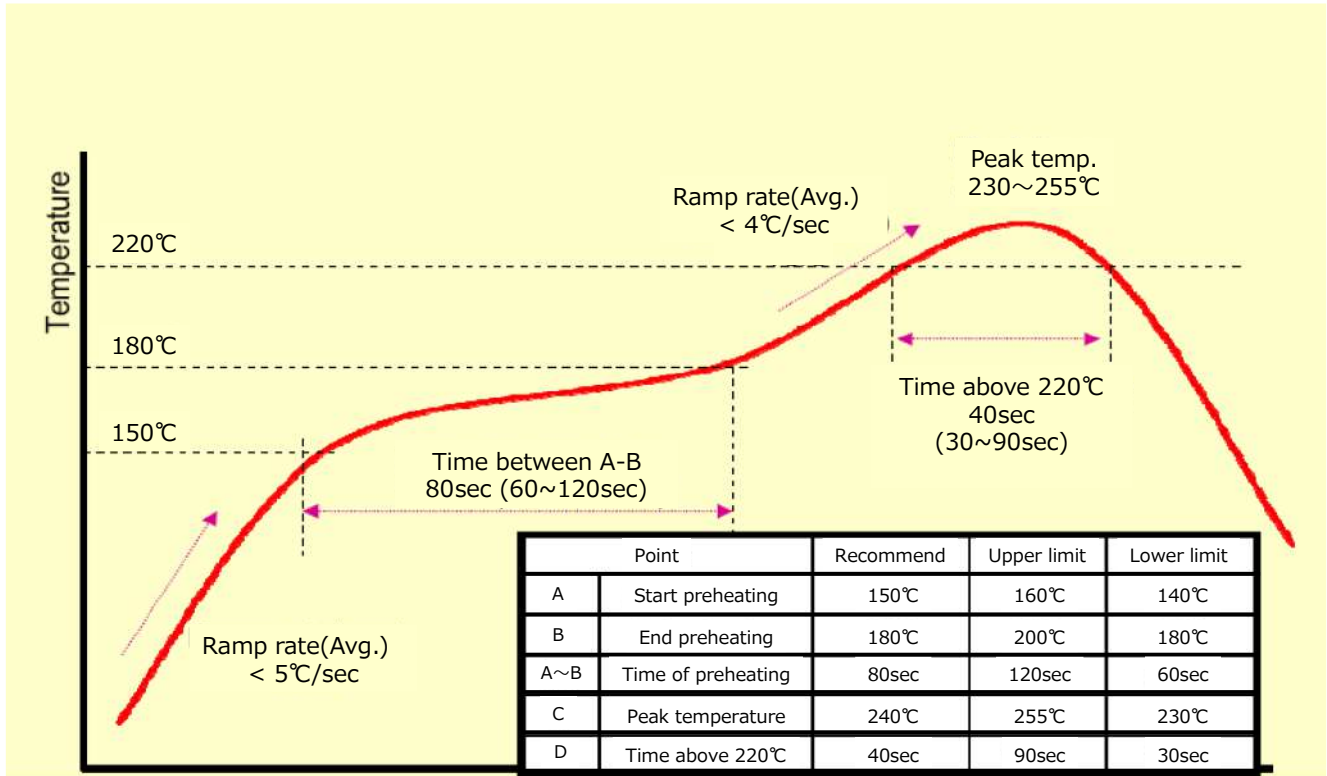

※Reflow solder can be operated only once

Fig.7. Recommended Reflow Profile

14. Packing

14.1. Taping dimensions

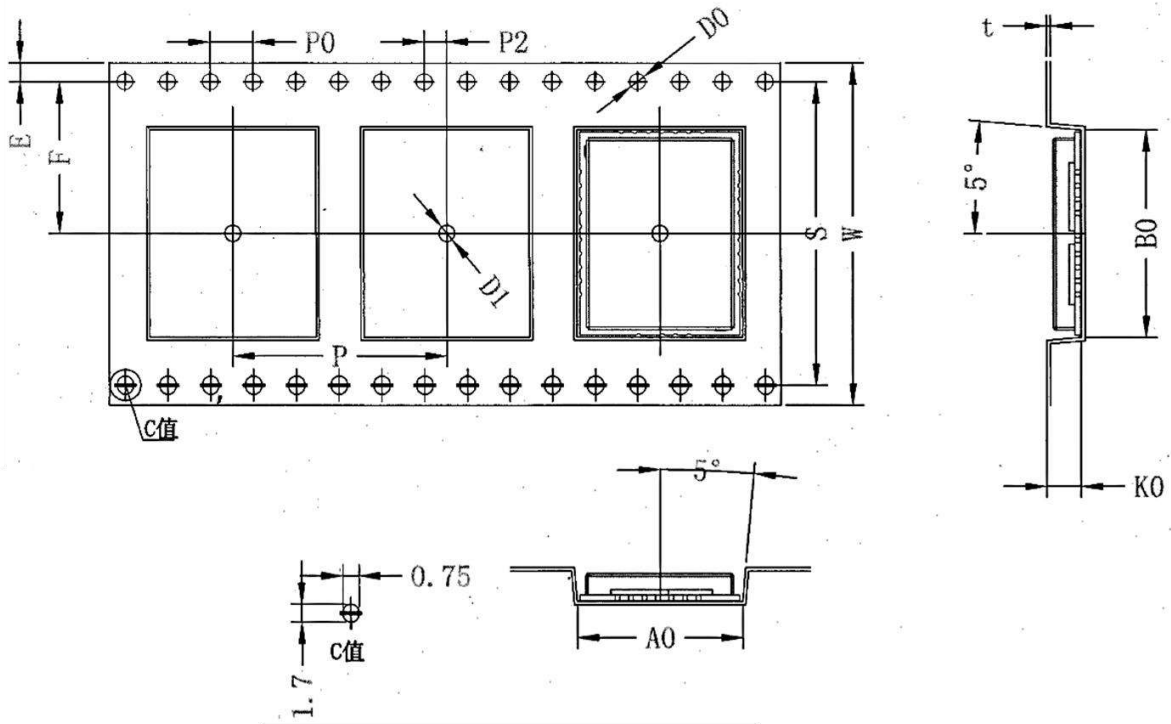

UNIT: mm

Symbol	A0	B0	D0	D1	E	F	P0	P	P2	K0	S	t	W
Dimensions (mm)	15.55	19.4	1.5	2.0	1.75	14.2	4.0	20.0	2.0	3.2	28.4	0.35	32.0
Tolerance (mm)	±0.1	±0.1	+0.1 / 0.0	MIN.	±0.1	±0.1	±0.1	±0.1	±0.1	±0.1	±0.1	±0.05	±0.3

<Material of tape> Pocket: PS, Cover tape: PE

14.2. Taping packaging specification

Pull-Out direction of taping and direction of pin 1 are shown below.

The taping of the products is done so that the adsorption side of the mounter may become a shield case side.

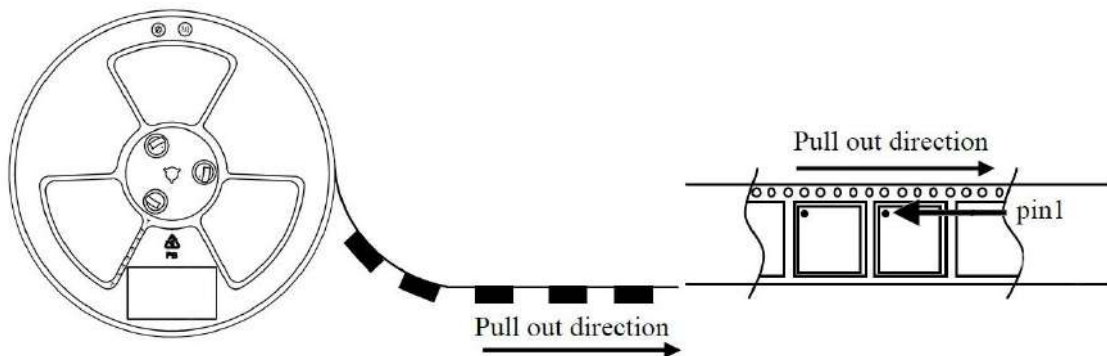

14.3. Packaging method

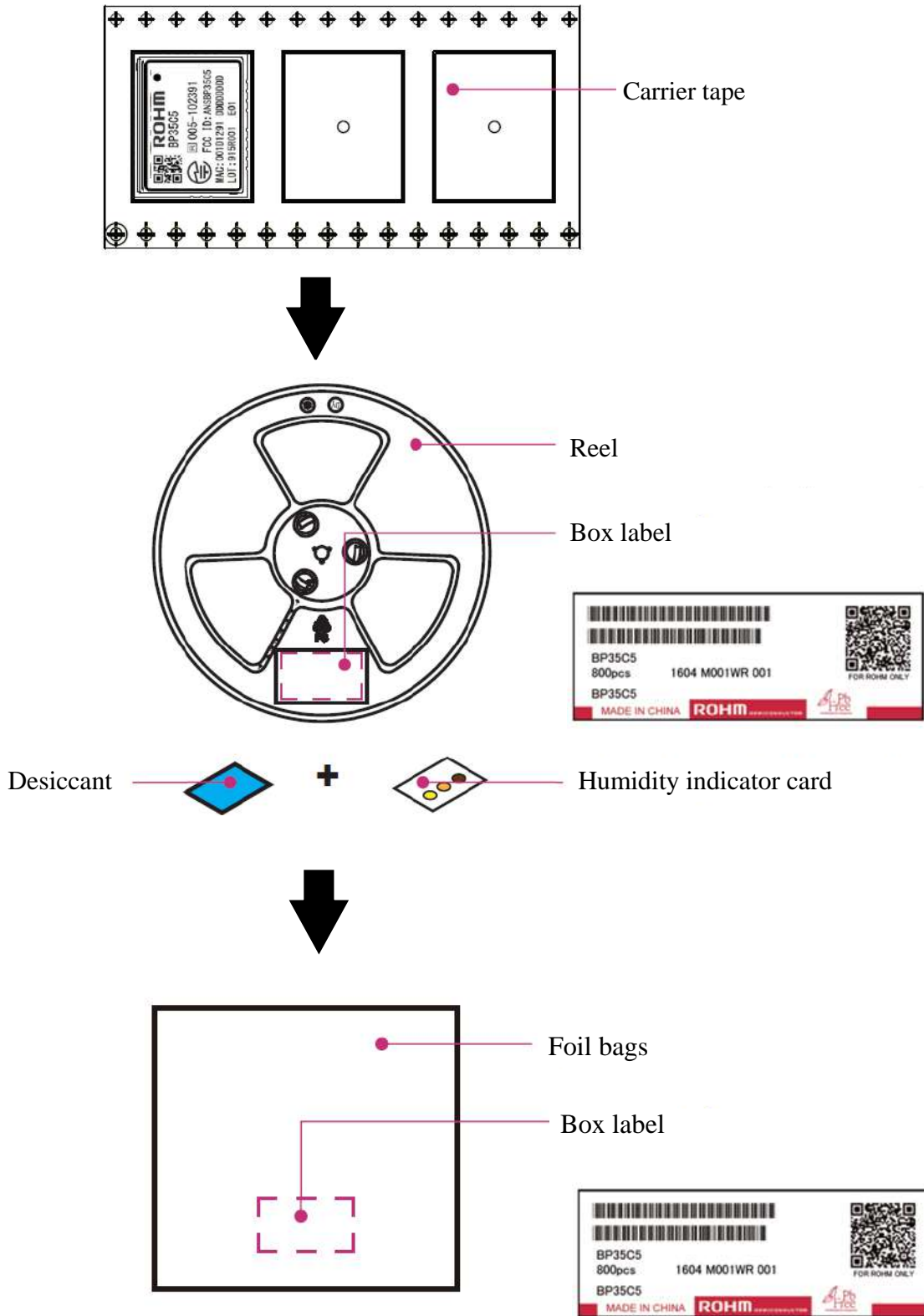

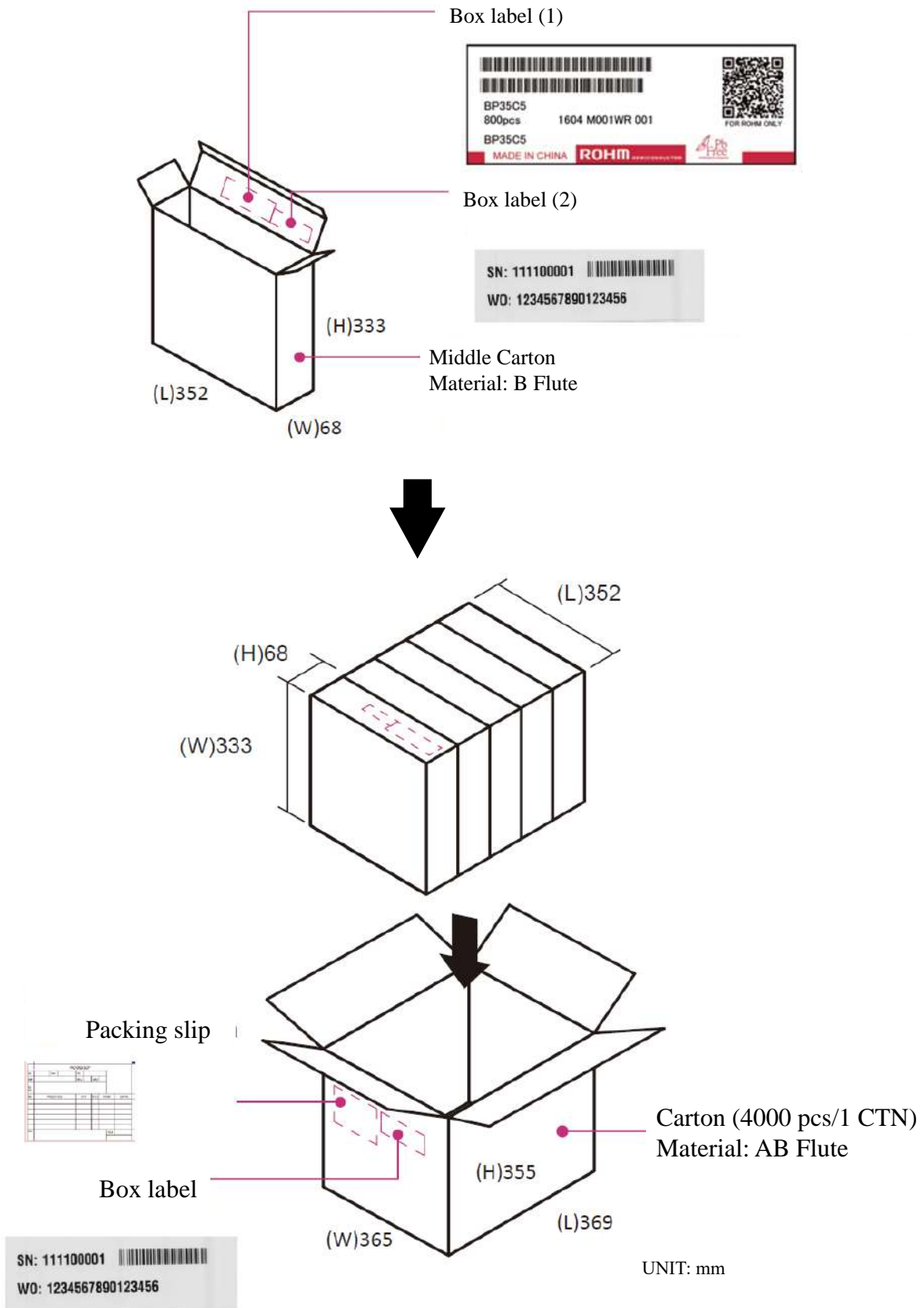

14.4. Reel Dimensions

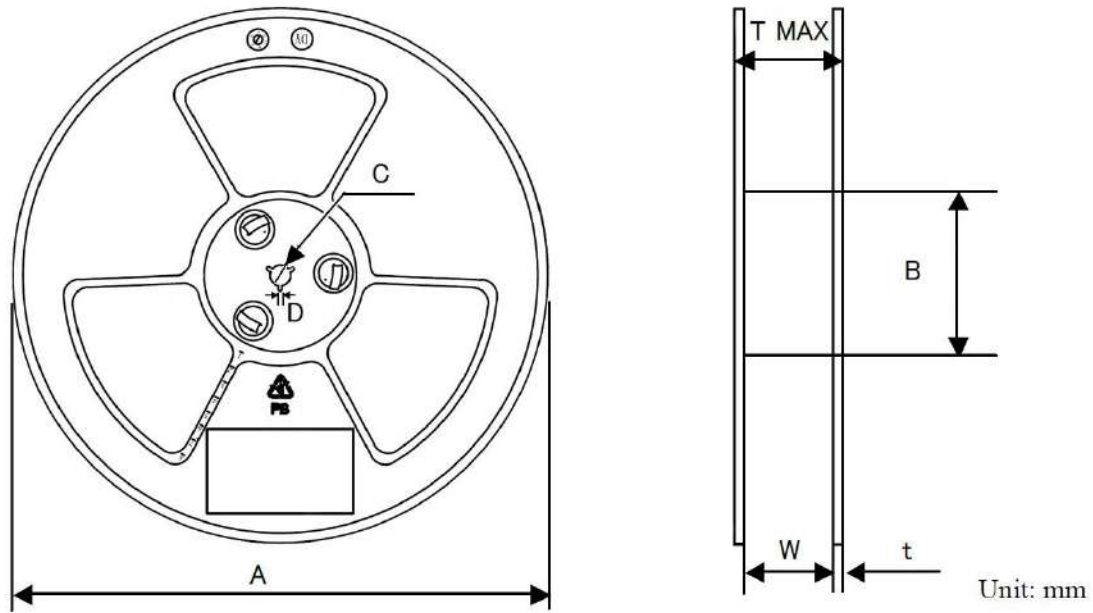

Reel size/ Tape size	A	B	C	D	W	t	T MAX
Dimensions (mm)	330	100	13.3	2.5	32.5	2.0	36
Tolerance (mm)	±2.0	±2.0	±1.0	±0.5	+2.0/ -0.0	±0.5	+2.0/ -1.0

14.5. Leader and Trail Tape

There will be 40 pockets at Leader tape.

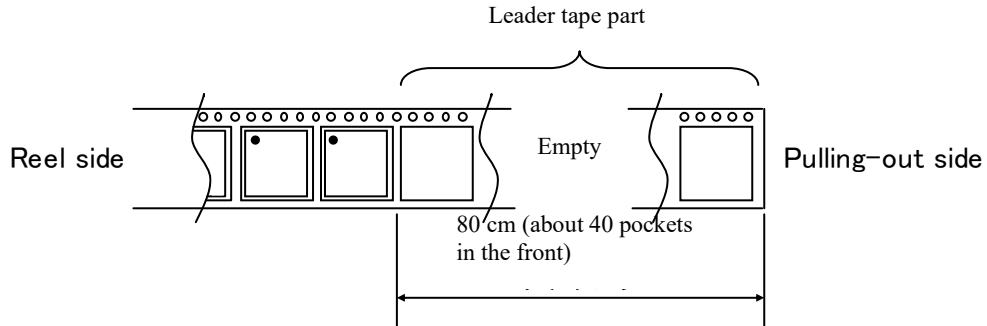

There will be 10 pockets at Trail tape.
The end of Trail tape is not fixed to Reel.

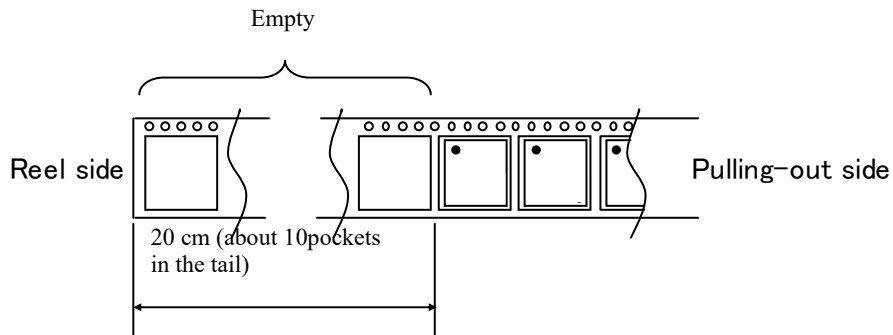

14.6. Missing product ratio

	Rate of incident	Remark
Consecutive missing products	0 place	Except Leader and Trail tapes
Non-Consecutive missing products	MAX. 1 pc / 1 reel	

14.7. Standard Packaging Quantity

Type	Package Quantity
BP35C5	800 pcs / reel

- Please be sure to order product with multiple number of the Standard Packaging Quantity.
- The quantity of "Standard Package Quantity" may change in future.

14.8. Peel-off strength of Cover Tape

Peel-off strength of Cover tape is: 0.1~0.7 N (10 gf~70 gf) with peeling speed of 300 mm/min.

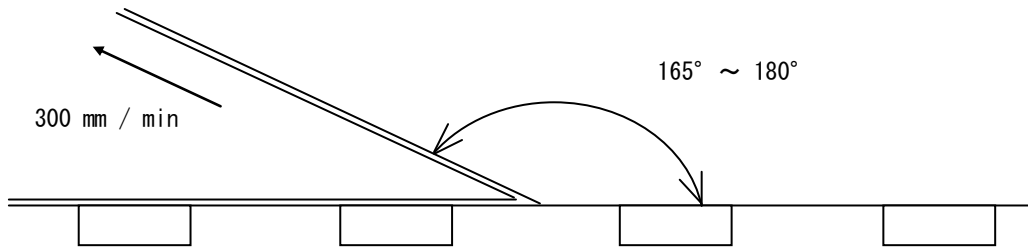

14.9. Packing Label

The label with following things is stuck at the packing case.

- ① Type name (BP35C5)
- ② Quantity
- ③ Lot No.
- ④ Shipment inspection stamp
- ⑤ Country of origin
- ⑥ Manufacturing company name (Trade mark)
- ⑦ Logotype of lead free

Please refer to the following example of the label indication.

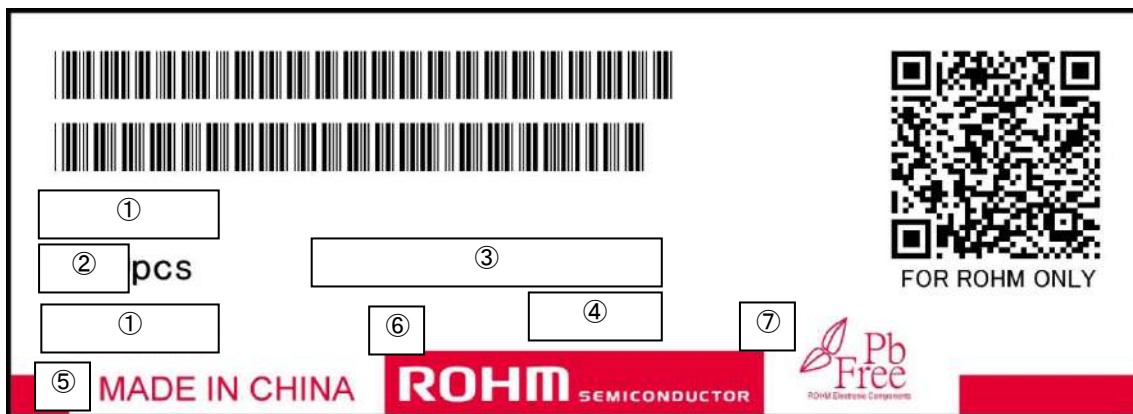

Fig.8. Packing Label Spec

15. Product Weight

1.4 gram

16. Manufacturing Country

China

17. Precautions for Use

- 1) This product allows the reflow process only once.
(with ROHM's recommended reflow condition)
During the reflow process, the solder inside the product may be re-fused or re-melt.
Please note this and pay special attention.
- 2) If this product is laid neglected, it will absorb moisture from the surrounding environment.
Keep this Product with below mentioned condition, and reflow mount it within 72 hours of opening the laminated bag.
<Store condition>
Temperature: 5 °C~40 °C
Relative Humidity: 50±10 %RH
- 3) If storage in the desiccator where is humidity under the recommended values, be sure to protect this product from static electricity.
- 4) Be sure to use after baking process with the following conditions when it passed 72 hours after opening.
•Baking condition: 125 °C / 24 hours (Not in reel state), Baking times: up to once
- 5) When a mounter is used to place this product, its recognition should be taken with the reverse side (pad) of product. It is not recommended to use the dimensions of product for recognition as its tolerance is big.
- 6) There are cases where lot numbers are different in the same reel.
- 7) There are cases where serial numbers (MAC address) are not in sequence in the same reel.
- 8) About soldering parts of mounting on this product, presence of soldering fillet does not be asked.
- 9) With respect to a label affixed to this product, defects other than "peeling", "sticking-out", and "extreme defect in character recognition" are overlooked.
- 10) This product is assumed to be mounted on glass epoxy board.
If the product is mounted on other materials board such as ceramic, be sure to evaluate it sufficiently.
- 11) RF-SW (pin 27, pin 29 ANT terminal) which is mounted inside the module is a product very weak to static electricity on the specification. Be sure to use after taking sufficient measures against static electricity.
- 12) Please note that it is likely to come off when the stress joins the shield case.
- 13) Use this product without cleaning residue of flux.
- 14) About wireless communication
 1. Wireless communication may be unstable due to radio wave environment and communication environment, does not guarantee 100 % data transfer, ROHM assumes absolutely no responsibility even if data is missing.
 2. UDP does not provide for the arrival of consecutive packet send data arrival is not guaranteed.
 3. Please fully verify with customers before installing this product in customer's set and doing full-scale operation.
 4. ROHM assumes no responsibility for any damage or malfunction caused by data interception, loss, theft, leakage to a third party.

18. Precautions as Radio Equipment

18.1. For Japan region (ARIB STD-T108)

This module has acquired the "Construction design certification" (Article 38-24 (1) of the Radio Act) for "Radio Equipment: Specified low power equipment of less than 13 GHz prescribed in Article 2-1 (8) Type of Specified Radio Equipment."

Consequently, this module is available for use as radio equipment only in Japan without making an application for radio station license.

- Construction Design Certification Number: 005-102391

To safely use this module as radio equipment, be sure to observe the following.

- 1) The marking of this Product indicates that it has acquired the "Technical Regulations Conformity Certification."
Do not erase the marking or affix any label on the marking.
- 2) Never disassembly or modify this Product. Doing so may be subject to punishment under the Radio Act.
- 3) To use the dedicated external antenna, contact your ROHM representative in advance.

18.2. For United States region (FCC Part 15C)

This module has received Federal Communications Commission (FCC) CFR47 Telecommunications, Part 15 Subpart C "Intentional Radiators" modular approval in accordance with Part 15.212 Modular Transmitter approval. Modular approval allows the end user to integrate the BP35C5 module into a finished product without obtaining subsequent and separate FCC approvals for intentional radiation, provided no changes or modifications are made to the module circuitry. Changes or modifications could void the user's authority to operate the equipment. The end user must comply with all of the instructions provided by the Grantee (ROHM), which indicate installation and/or operating conditions necessary for compliance.

The finished product is required to comply with all applicable FCC equipment authorizations regulations, requirements and equipment functions not associated with the transmitter module portion. For example, compliance must be demonstrated to regulations for other transmitter components within the host product; to requirements for unintentional radiators (Part 15 Subpart B "Unintentional Radiators"), such as digital devices, computer peripherals, radio receivers, etc.; and to additional authorization requirements for the non-transmitter functions on the transmitter module (i.e., Verification, or Declaration of Conformity) (e.g., transmitter modules may also contain digital logic functions) as appropriate.

18.2.1. Labeling and User Information Requirements

This module has been labeled with its own FCC ID number, and if the FCC ID is not visible when the module is installed inside another device, then the outside of the finished product into which the module is installed must also display a label referring to the enclosed module. This exterior label can use wording as follows:

Contains Transmitter Module FCC ID: ANSBP35C5
or
Contains FCC ID: ANSBP35C5

This device complies with Part 15 of the FCC Rules. Operation is subject to the following two conditions:
(1) this device may not cause harmful interference, and (2) this device must accept any interference received, including interference that may cause undesired operation.

A user's manual for the finished product should include the following statement:

This equipment has been tested and found to comply with the limits for a Class B digital device, pursuant to part 15 of the FCC Rules. These limits are designed to provide reasonable protection against harmful interference in a residential installation. This equipment generates uses and can radiate radio frequency energy, and if not installed and used in accordance with the instructions, may cause harmful interference to radio communications. However, there is no guarantee that interference will not occur in a particular installation. If this equipment does cause harmful interference to radio or television reception, which can be determined by turning the equipment off and on, the user is encouraged to try to correct the interference by one or more of the following measures:

- Reorient or relocate the receiving antenna.
- Increase the separation between the equipment and receiver.
- Connect the equipment into an outlet on a circuit different from that to which the receiver is connected.
- Consult the dealer or an experienced radio/TV technician for help.

Additional information on labeling and user information requirements for Part 15 devices can be found in KDB Publication 784748 available at the FCC Office of Engineering and Technology (OET) Laboratory Division Knowledge Database (KDB) <https://apps.fcc.gov/oetcf/kdb/index.cfm>

18.2.2. RF Exposure

All transmitters regulated by FCC must comply with RF exposure requirements. KDB 447498 General RF Exposure Guidance provides guidance in determining whether proposed or existing transmitting facilities, operations or devices comply with limits for human exposure to Radio Frequency (RF) fields adopted by the Federal Communications Commission (FCC).

From this module FCC Grant: Output power listed is conducted. This grant is valid only when the module is sold to OEM integrators and must be installed by the OEM or OEM integrators. This transmitter is restricted for use with the specific antenna(s) tested in this application for Certification and must not be co-located or operating in conjunction with any other antenna or transmitters within a host device, except in accordance with FCC multi-transmitter product procedures.

18.2.3. Approved External Antenna Types

To maintain modular approval in the United States, only the antenna types that have been tested shall be used. It is permissible to use different antenna manufacturer provided the same antenna type and antenna gain (equal to or less than) is used. Testing of this module was performed with the antenna types listed in Table 1 Tested External Antenna Types.

TABLE 1: Tested External Antenna Types

Type	Gain (dBi)
Dipole	+3

18.2.4. RF Trace Layout Design

This modular transmitter is certified with a PCB edge SMA connector and micro-strip trace layout as shown in the following figure. The host PCB can follow this trace design to maintain compliance under the modular grant (FCC).

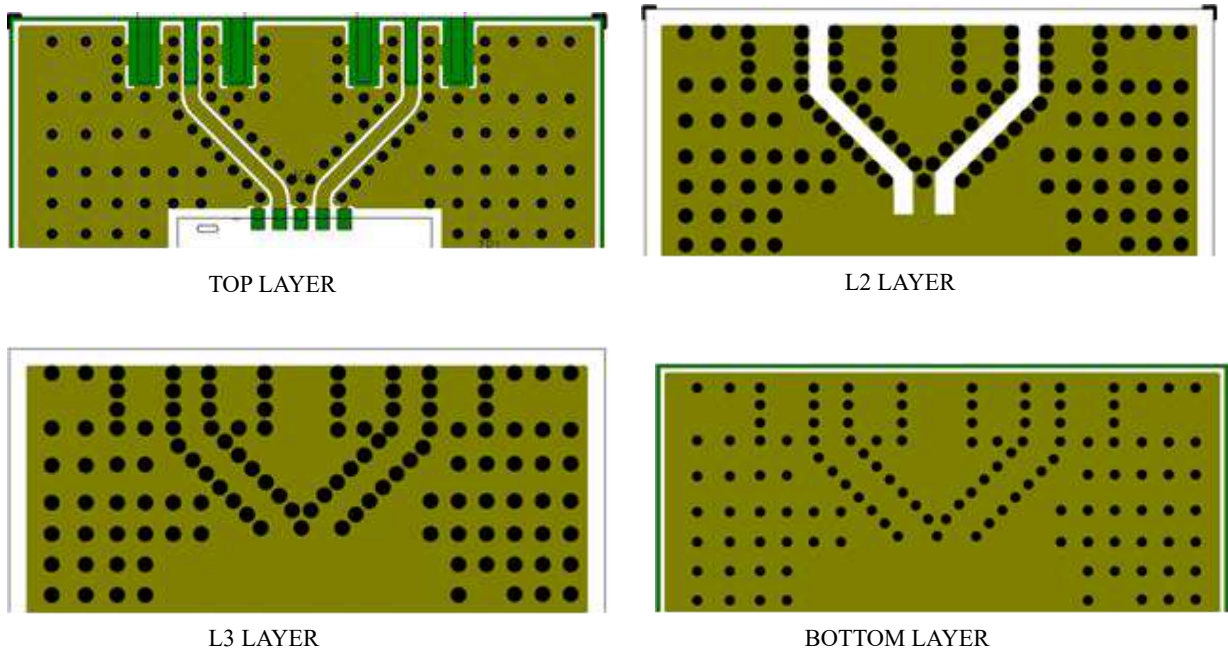

PCB details:
 4 layer through hole
 FR-4
 Thickness: 1.2 mm

Fig.9. RF trace routing

19. Firmware

19.1. Firmware licensing

With respect to the built-in firmware of this Product, agree to the following licensing prior to use.

- 1) This software is firmware dedicated to BP35C5. Do not use the firmware for any product other than BP35C5.
- 2) Do not assign, transfer, sub-license, or lend this Software to any third parties.
- 3) Reverse engineering, decompilation, disassembly, reproduction, and change of this Software are prohibited.
- 4) ROHM shall not guarantee any and all operations performed by using this Software.
- 5) Since this software will be updated, be sure to implement the update function of this software on the customer's set main unit. Please inquire about the update method separately.
- 6) In the event of a defect or the like to be attributed to ROHM under normal use for the Software during the first six (6) months from (1) Initial delivery date of BP35C5 or (2) Date of this specification change, customer must notify ROHM immediately.
- 7) Please note that ROHM does not pay any costs (including but not limited to outsourcing expenses, repair expenses, product collection expenses, alternative procurement costs, etc.) paid by customers from third parties due to defects etc. without prior consent of ROHM.
- 8) In any case, the amount borne by ROHM due to defects etc. of the software shall be no more than the last six (6) months of the total sales value of BP35C5 from ROHM to the customer.
- 9) If the provisions of Article 19.1 of this specification, the provisions of the basic contract to be concluded, any contracts and memoranda, incidental thereto, and other specifications of this specification between customer and ROHM contradict or conflict, the provisions of this section shall prevail.

19.2. Firmware version

- 1) The version of firmware written to this Product is the latest version at the time when it is manufactured.
- 2) Firmware may not be the latest version depending on the shipment timing.
- 3) The version of firmware is subject to change without prior notice. ROHM shall not be in any way responsible or liable for damages of customers caused by such changes.
- 4) The version of firmware written to this Product cannot be distinguished by the appearance of the Product.
- 5) The same firmware is written to products contained in the same package.

19.3. Method for checking firmware version

Firmware version can be checked by using "vers" command.

For details, refer to information in command manual.

19.4. Number of rewritable firmware

The maximum number of times that the firmware of this Product can be rewritten is 1,000 times. If you rewrite the firmware beyond this number, ROHM will not guarantee the operation of this Product.

20. Notice

● Precaution on using ROHM Products

- 1) Our Products are designed and manufactured for application in ordinary electronic equipment (such as AV equipment, OA equipment, telecommunication equipment, home electronics appliances, amusement equipment, etc.). If you intend to use our Products in devices requiring extremely high reliability (such as medical equipment, transport equipment, traffic equipment, aircraft/spacecraft, nuclear power controllers, fuel controllers, car equipment including car accessories, safety devices, etc.) and whose malfunction or failure may cause loss of human life, bodily injury or serious damage to property ("Special Applications"), please consult with the ROHM sales representative in advance. Unless otherwise agreed in writing by ROHM in advance, ROHM shall not be in any way responsible or liable for any damages, expenses or losses incurred by you or third parties arising from the use of any ROHM's Products for Specific Applications.

- 2) ROHM designs and manufactures its Products subject to strict quality control system. However, semiconductor products can fail or malfunction at a certain rate. Please be sure to implement, at your own responsibilities, adequate safety measures including but not limited to fail-safe design against the physical injury, damage to any property, which a failure or malfunction of our Products may cause. The following are examples of safety measures.
 - [a] Installation of protection circuits or other protective devices to improve system safety
 - [b] Installation of redundant circuits to reduce the impact of single or multiple circuit failure

- 3) Our Products are designed and manufactured for use under standard conditions and not under any special or extraordinary environments or conditions, as exemplified below. Accordingly, ROHM shall not be in any way responsible or liable for any damages, expenses or losses arising from the use of any ROHM's Products under any special or extraordinary environments or conditions. If you intend to use our Products under any special or extraordinary environments or conditions (as exemplified below), your independent verification and confirmation of product performance, reliability, etc, prior to use, must be necessary:
 - [a] Use of our Products in any types of liquid, including water, oils, chemicals, and organic solvents
 - [b] Use of our Products outdoors or in places where the Products are exposed to direct sunlight or dust
 - [c] Use of our Products in places where the Products are exposed to sea winds or corrosive gases, including Cl₂, H₂S, NH₃, SO₂, and NO₂
 - [d] Use of our Products in places where the Products are exposed to static electricity or electromagnetic waves
 - [e] Use of our Products in proximity to heat-producing components, plastic cords, or other flammable items
 - [f] Sealing or coating our Products with resin or other coating materials
 - [g] Use of the Products in places subject to dew condensation

- 4) The Products are not subject to radiation-proof design.
- 5) Please verify and confirm characteristics of the final or mounted products in using the Products.
- 6) Confirm that operation temperature is within the specified range described in the product specification.
- 7) ROHM shall not be in any way responsible or liable for failure induced under deviant condition from what is defined in this document.
- 8) This Product may be subjected to radio wave interference from other equipment emitting radio waves.
- 9) This Product emits radio waves due to the specification. To use equipment emitting radio waves, certification under the Radio Act should be obtained by region in which the Product is used. For the standards for certification under the Radio Act to be obtained for the use of this Product, separately contact your ROHM representative.

● Precaution for Mounting / Circuit board design

- 1) When a highly active halogenous (chlorine, bromine, etc.) flux is used, the residue of flux may negatively affect product performance and reliability.
- 2) In principle, the reflow soldering method must be used.

● Precautions Regarding Application Examples and External Circuits

- 1) If change is made to the constant of an external circuit, please allow a sufficient margin considering variations of the characteristics of the Products and external components, including transient characteristics, as well as static characteristics.
- 2) You agree that application notes, reference designs, and associated data and information contained in this document are presented only as guidance for Products use. Therefore, in case you use such information, you are solely responsible for it and you must exercise your own independent verification and judgment in the use of such information contained in this document. ROHM shall not be in any way responsible or liable for damages, expenses or losses incurred by you or third parties arising from the use of such information.

● Precaution for Electrostatic

This Product is electrostatic sensitive product, which may be damaged due to electrostatic discharge. Please take proper caution in your manufacturing process and storage so that voltage exceeding Products maximum rating will not be applied to Products. Please take special care under dry condition (e.g. Grounding of human body / equipment / solder iron, isolation from charged objects, setting of Ionizer, friction pREV. Antion and temperature / humidity control).

● Precaution for Storage / Transportation

- 1) Product performance and soldered connections may deteriorate if the Products are stored in the places where:
 - [a] the Products are exposed to sea winds or corrosive gases, including Cl₂, H₂S, NH₃, SO₂, and NO₂
 - [b] the temperature or humidity exceeds those recommended by ROHM
Temperature: 5°C - 40°C, Humidity: 40% - 60%RH
 - [c] the Products are exposed to direct sunshine or condensation
 - [d] the Products are exposed to high Electrostatic
- 2) Even under ROHM recommended storage condition, solderability of products out of recommended storage time period may be degraded.
It is strongly recommended to confirm solderability before using Products of which storage time is exceeding the recommended storage time period.
•Recommended storage condition: Temperature: 5°C - 40°C, Humidity: 40% - 60%RH
- 3) Store / transport cartons in the correct direction, which is indicated on a carton as a symbol. Otherwise bent leads may occur due to excessive stress applied when dropping of a carton.
- 4) Use Products within the specified time after opening a humidity barrier bag. Baking is required before using Products of which storage time is exceeding the recommended storage time period.
•Maximum time : 72 hours, Temperature: 5°C - 40°C, Humidity: 40% - 60%RH
•Baking condition: Single type: 125°C, 24 hours, up to once

● Precaution for product label

QR code printed on ROHM product label is for ROHM's internal use only, and please do not use at customer site.

● Precaution for disposition

When disposing Products please dispose them properly using an authorized industry waste company.

● Precautions Regarding Intellectual Property Rights

- 1) All information and data including but not limited to application example contained in this document is for reference only. ROHM does not warrant that foregoing information or data will not infringe any intellectual property rights or any other rights of any third party regarding such information or data.
- 2) ROHM shall not have any obligations where the claims, actions or demands arising from the combination of the Products with other articles such as components, circuits, systems or external equipment (including software)
- 3) No license, expressly or implied, is granted hereby under any intellectual property rights or other rights of ROHM or any third parties with respect to the Products or the information contained in this document. Provided, however, that ROHM will not assert its intellectual property rights or other rights against you or your customers to the extent necessary to manufacture or sell products containing the Products, subject to the terms and conditions herein.

● Other Matters

- 1) This document may not be reprinted or reproduced, in whole or in part, without prior written consent of ROHM.
- 2) The Products may not be disassembled, converted, modified, reproduced or otherwise changed without prior written consent of ROHM.
- 3) In no event shall you use in any way whatsoever the Products and the related technical information contained in the Products or this document for any military purposes, including but not limited to, the development of mass-destruction weapons.
- 4) The proper names of companies or products described in this document are trademarks of registered trademarks of ROHM, its affiliated companies or third parties.

● Precautions on this datasheet

- 1) The content described in this specification is at the time of issuing this specification and may be changed without notice
- 2) The information in this specification is carefully prepared for accuracy, but is not guaranteed to be error-proof. If the damage caused by the error of the information contained in this specification is caused to the customer, the company assumes no responsibility at all.
- 3) The company shall not be liable for any infringement of the third party's patent rights, copyrights or other intellectual property rights arising out of the use of the technical information described in this specification. Based on this specification, we do not grant any patent rights, copyrights or other intellectual property rights of the Company or third parties.
- 4) Please refrain from reproducing or reproducing all or part of this specification without the prior consent of the company.

21. Revision History

Rev.	Date	Contents
001	22.June.2020	New Issue
002	23.Oct.2020	•Delete of "sleep state current consumption" •Delete of "startup time"
003	4.Nov.2020	•Corrected the PIN name in the "Block Diagram". •Corrected the PIN name in the "Reference Peripheral Circuit Diagrams".

Notice

Precaution on using ROHM Products

- Our Products are designed and manufactured for application in ordinary electronic equipment (such as AV equipment, OA equipment, telecommunication equipment, home electronic appliances, amusement equipment, etc.). If you intend to use our Products in devices requiring extremely high reliability (such as medical equipment ^(Note 1), transport equipment, traffic equipment, aircraft/spacecraft, nuclear power controllers, fuel controllers, car equipment including car accessories, safety devices, etc.) and whose malfunction or failure may cause loss of human life, bodily injury or serious damage to property ("Specific Applications"), please consult with the ROHM sales representative in advance. Unless otherwise agreed in writing by ROHM in advance, ROHM shall not be in any way responsible or liable for any damages, expenses or losses incurred by you or third parties arising from the use of any ROHM's Products for Specific Applications.

(Note1) Medical Equipment Classification of the Specific Applications

JAPAN	USA	EU	CHINA
CLASS III	CLASS III	CLASS II b	CLASS III
CLASS IV		CLASS III	

- ROHM designs and manufactures its Products subject to strict quality control system. However, semiconductor products can fail or malfunction at a certain rate. Please be sure to implement, at your own responsibilities, adequate safety measures including but not limited to fail-safe design against the physical injury, damage to any property, which a failure or malfunction of our Products may cause. The following are examples of safety measures:
 - Installation of protection circuits or other protective devices to improve system safety
 - Installation of redundant circuits to reduce the impact of single or multiple circuit failure
- Our Products are designed and manufactured for use under standard conditions and not under any special or extraordinary environments or conditions, as exemplified below. Accordingly, ROHM shall not be in any way responsible or liable for any damages, expenses or losses arising from the use of any ROHM's Products under any special or extraordinary environments or conditions. If you intend to use our Products under any special or extraordinary environments or conditions (as exemplified below), your independent verification and confirmation of product performance, reliability, etc. prior to use, must be necessary:
 - Use of our Products in any types of liquid, including water, oils, chemicals, and organic solvents
 - Use of our Products outdoors or in places where the Products are exposed to direct sunlight or dust
 - Use of our Products in places where the Products are exposed to sea wind or corrosive gases, including Cl₂, H₂S, NH₃, SO₂, and NO₂
 - Use of our Products in places where the Products are exposed to static electricity or electromagnetic waves
 - Use of our Products in proximity to heat-producing components, plastic cords, or other flammable items
 - Sealing or coating our Products with resin or other coating materials
 - Use of our Products without cleaning residue of flux (Exclude cases where no-clean type fluxes is used. However, recommend sufficiently about the residue.) ; or Washing our Products by using water or water-soluble cleaning agents for cleaning residue after soldering
 - Use of the Products in places subject to dew condensation
- The Products are not subject to radiation-proof design.
- Please verify and confirm characteristics of the final or mounted products in using the Products.
- In particular, if a transient load (a large amount of load applied in a short period of time, such as pulse, is applied, confirmation of performance characteristics after on-board mounting is strongly recommended. Avoid applying power exceeding normal rated power; exceeding the power rating under steady-state loading condition may negatively affect product performance and reliability.
- De-rate Power Dissipation depending on ambient temperature. When used in sealed area, confirm that it is the use in the range that does not exceed the maximum junction temperature.
- Confirm that operation temperature is within the specified range described in the product specification.
- ROHM shall not be in any way responsible or liable for failure induced under deviant condition from what is defined in this document.

Precaution for Mounting / Circuit board design

- When a highly active halogenous (chlorine, bromine, etc.) flux is used, the residue of flux may negatively affect product performance and reliability.
- In principle, the reflow soldering method must be used on a surface-mount products, the flow soldering method must be used on a through hole mount products. If the flow soldering method is preferred on a surface-mount products, please consult with the ROHM representative in advance.

For details, please refer to ROHM Mounting specification

Precautions Regarding Application Examples and External Circuits

1. If change is made to the constant of an external circuit, please allow a sufficient margin considering variations of the characteristics of the Products and external components, including transient characteristics, as well as static characteristics.
2. You agree that application notes, reference designs, and associated data and information contained in this document are presented only as guidance for Products use. Therefore, in case you use such information, you are solely responsible for it and you must exercise your own independent verification and judgment in the use of such information contained in this document. ROHM shall not be in any way responsible or liable for any damages, expenses or losses incurred by you or third parties arising from the use of such information.

Precaution for Electrostatic

This Product is electrostatic sensitive product, which may be damaged due to electrostatic discharge. Please take proper caution in your manufacturing process and storage so that voltage exceeding the Products maximum rating will not be applied to Products. Please take special care under dry condition (e.g. Grounding of human body / equipment / solder iron, isolation from charged objects, setting of Ionizer, friction prevention and temperature / humidity control).

Precaution for Storage / Transportation

1. Product performance and soldered connections may deteriorate if the Products are stored in the places where:
 - [a] the Products are exposed to sea winds or corrosive gases, including Cl₂, H₂S, NH₃, SO₂, and NO₂
 - [b] the temperature or humidity exceeds those recommended by ROHM
 - [c] the Products are exposed to direct sunshine or condensation
 - [d] the Products are exposed to high Electrostatic
2. Even under ROHM recommended storage condition, solderability of products out of recommended storage time period may be degraded. It is strongly recommended to confirm solderability before using Products of which storage time is exceeding the recommended storage time period.
3. Store / transport cartons in the correct direction, which is indicated on a carton with a symbol. Otherwise bent leads may occur due to excessive stress applied when dropping of a carton.
4. Use Products within the specified time after opening a humidity barrier bag. Baking is required before using Products of which storage time is exceeding the recommended storage time period.

Precaution for Product Label

A two-dimensional barcode printed on ROHM Products label is for ROHM's internal use only.

Precaution for Disposition

When disposing Products please dispose them properly using an authorized industry waste company.

Precaution for Foreign Exchange and Foreign Trade act

Since concerned goods might be fallen under listed items of export control prescribed by Foreign exchange and Foreign trade act, please consult with ROHM in case of export.

Precaution Regarding Intellectual Property Rights

1. All information and data including but not limited to application example contained in this document is for reference only. ROHM does not warrant that foregoing information or data will not infringe any intellectual property rights or any other rights of any third party regarding such information or data.
2. ROHM shall not have any obligations where the claims, actions or demands arising from the combination of the Products with other articles such as components, circuits, systems or external equipment (including software).
3. No license, expressly or implied, is granted hereby under any intellectual property rights or other rights of ROHM or any third parties with respect to the Products or the information contained in this document. Provided, however, that ROHM will not assert its intellectual property rights or other rights against you or your customers to the extent necessary to manufacture or sell products containing the Products, subject to the terms and conditions herein.

Other Precaution

1. This document may not be reprinted or reproduced, in whole or in part, without prior written consent of ROHM.
2. The Products may not be disassembled, converted, modified, reproduced or otherwise changed without prior written consent of ROHM.
3. In no event shall you use in any way whatsoever the Products and the related technical information contained in the Products or this document for any military purposes, including but not limited to, the development of mass-destruction weapons.
4. The proper names of companies or products described in this document are trademarks or registered trademarks of ROHM, its affiliated companies or third parties.

General Precaution

1. Before you use our Products, you are requested to carefully read this document and fully understand its contents. ROHM shall not be in any way responsible or liable for failure, malfunction or accident arising from the use of any ROHM's Products against warning, caution or note contained in this document.
2. All information contained in this document is current as of the issuing date and subject to change without any prior notice. Before purchasing or using ROHM's Products, please confirm the latest information with a ROHM sales representative.
3. The information contained in this document is provided on an "as is" basis and ROHM does not warrant that all information contained in this document is accurate and/or error-free. ROHM shall not be in any way responsible or liable for any damages, expenses or losses incurred by you or third parties resulting from inaccuracy or errors of or concerning such information.