

# User Guide

## Sterling-LWB(5) SD Card Board

*Version 1.1*

---



## REVISION HISTORY

Version	Date	Notes	Approver
1.0	12 April 2017	Initial Release	Andrew Dobbing
1.1	14 Nov 2017	Added Sterling-LWB5 SD Card	Robert Gosewehr

## CONTENTS

1	Introduction.....	4
1.1.	Purpose and Scope .....	4
1.2.	Applicable Documents.....	4
2	Sterling-LWB (5) SD Card Board Description .....	4
3	Sterling-LWB (5) SD Card Board Hardware.....	6
3.1.	Interface Connectors .....	6
3.2.	Development Board Power .....	7
4	Development Board Host Software Configuration.....	8
5	Contacting Laird.....	9

## 1 INTRODUCTION

### 1.1. Purpose and Scope

The purpose of this document is to provide details regarding the setup of the Sterling-LWB and Sterling-LWB5 module on the SD card board. This document covers a description of the SD card board and its features.

### 1.2. Applicable Documents

The following documents are available from the [Sterling-LWB product page](#):

- Sterling-LWB Datasheet
- How-to Guide – *Integrating Laird Sterling-LWB Wi-Fi and Bluetooth with Freescale i.MX 6 UltraLite Evaluation Kit Under Linux*

The following documents are available from the [Sterling-LWB5 product page](#):

- Sterling-LWB5 Datasheet
- Sterling-LWB5 Application Guide
- How-to Guide – *Integrating Laird Sterling-LWB Wi-Fi and Bluetooth with Freescale i.MX 6 UltraLite Evaluation Kit Under Linux – Note: This guide also works for the Sterling-LWB5.*

## 2 STERLING-LWB (5) SD CARD BOARD DESCRIPTION

The Sterling-LWB & Sterling-LWB5 SD Card development board is an evaluation and development board for the Laird Sterling-LWB and Sterling-LWB5 module. It connects to a standard SDIO card slot on a host board and can be powered directly from the SD card slot or from an external power supply. Additionally, it brings out all necessary GPIO pins for Wi-Fi operation and all necessary pins for Bluetooth operation including PCM audio pins. This allows the board to be connected to any development board with an available SD card slot. The board allows for quick prototyping of designs using the Laird Sterling-LWB and Sterling-LWB5 modules.

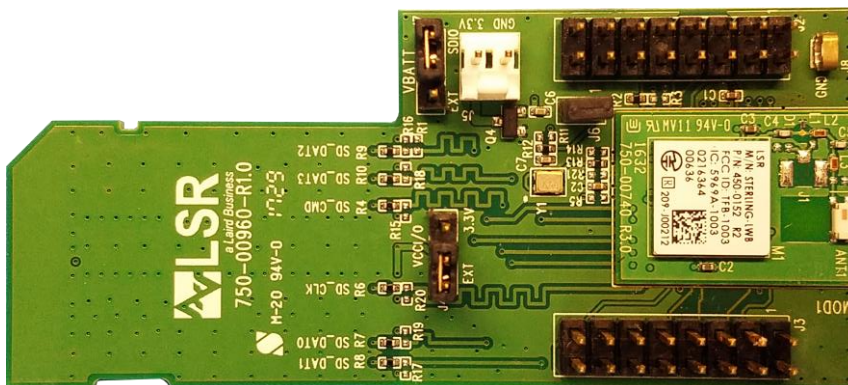

Figure 1: Sterling-LWB Chip Antenna SD card board

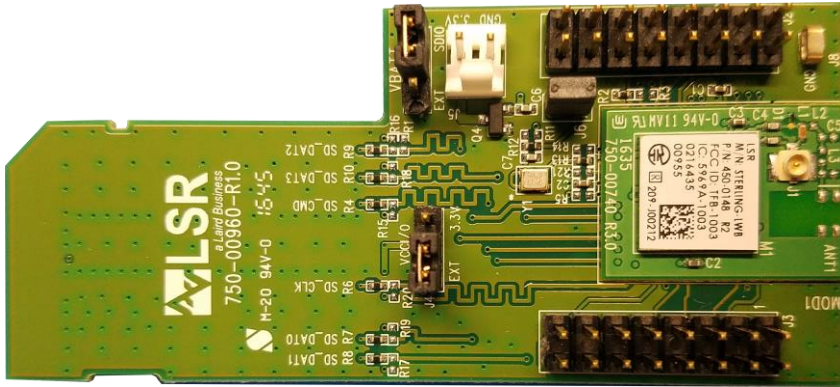

Figure 2: Sterling-LWB U.FL SD card board

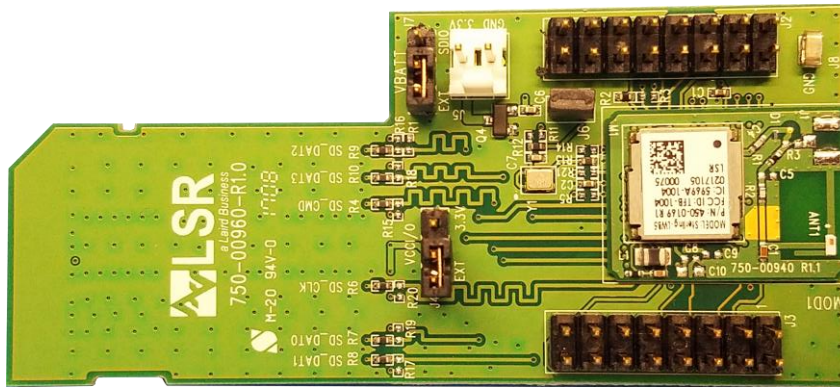

Figure 3: Sterling-LWB5 Chip Antenna SD card board

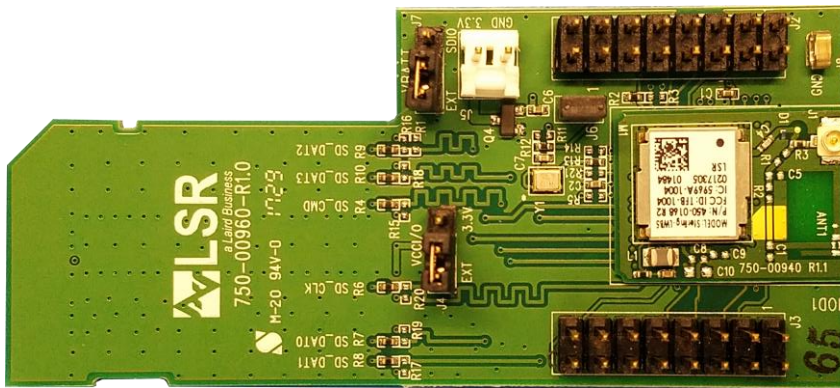

Figure 4: Sterling-LWB5 U.FL SD card board

### 3 STERLING-LWB (5) SD CARD BOARD HARDWARE

See the LSR website for the full PCB, schematic, and BOM of the Sterling-LWB & Sterling-LWB5 SD card board:

Sterling-LWB

<https://www.lsr.com/embedded-wireless-modules/wifi-plus-bluetooth-module/sterling-lwb>

Sterling-LWB5

<https://www.lsr.com/embedded-wireless-modules/wifi-plus-bluetooth-module/sterling-lwb5>

#### 3.1. Interface Connectors

The Laird Sterling-LWB and Sterling-LWB5 SD card board has two connectors (J2 and J3) for interfacing with the host development board. This provides all necessary pins to completely connect the module to the host for both Wi-Fi and Bluetooth operation.

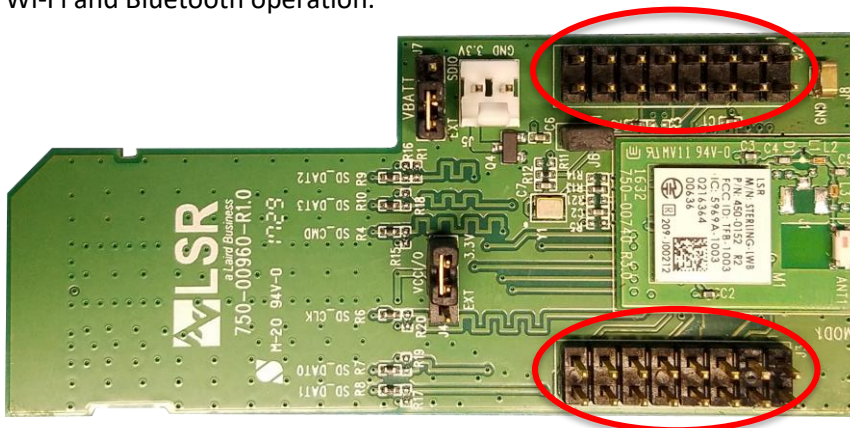

**Figure 5: Sterling-LWB SD card board connectors**

**Table 1: Connector J2 pinout**

J2 Pin Number	Pin Name	Description
1	VIN_3V3	3.3V Input Voltage
2	WIFI_GPIO_1	Wi-Fi GPIO 1 from the module
3	WL_HOST_WAKE	Wi-Fi host wake signal
4	WIFI_GPIO_2	Wi-Fi GPIO 2 from the module
5	NC	No Connect
6	WIFI_GPIO_3	Wi-Fi GPIO 3 from the module
7	NC	No Connect
8	BT_GPIO_5	Bluetooth GPIO 5 from the module
9	EXT_32KHZ_CLK	32KHz Clock
10	WIFI_GPIO_4	Wi-Fi GPIO 4 from the module
11	CLK_REQ	Wi-Fi SDIO clock request
12	NC	No Connect
13	NC	No Connect
14	NC	No Connect
15	NC	No Connect
16	GND	Ground



Table 2: Connector J3 pinout

J3 Pin Number	Pin Name	Description
1	VIN_EXT	External Supply Voltage
2	VCC_IO_EXT	External I/O Voltage Supply
3	BT_HOST_WAKE	Bluetooth host wake signal from module
4	BT_PCM_CLK	PCM Clock Input
5	BT_PCM_SYNC	PCM Frame Synch Signal
6	BT_UART_CTS_HST_RTS	Module Bluetooth UART CTS signal (host RTS signal)
7	BT_PCM_IN	PCM Input Signal
8	BT_UART_TXD_HOST_RXD	Module Bluetooth UART transmit pin (host receive pin)
9	BT_PCM_OUT	PCM Output Signal
10	BT_UART_RXD_HST_TXD	Module Bluetooth UART receive pin (host transmit pin)
11	WREG_ON	Wi-Fi Enable
12	NC	Not Connected
13	BT_REG_ON	Module Bluetooth enable signal
14	BT_UART_RTS_HST_CTS	Module Bluetooth UART RTS signal (host CTS signal)
15	BT_DEV_WAKE	Bluetooth device wake signal from host
16	GND	Ground

**Note:** Pin Layout is the same for the Sterling-LWB5 version of the SD Card

### 3.2. Development Board Power

The Sterling-LWB & Sterling-LWB5 SD card boards provide two possible sources for powering the board 3.3V. Power can be provided from an external power supply on J5 or from the SD card bus (Pin 4). Jumper J7 is used to select which power supply is used. Sterling-LWB is setup in the 3.3V position when shipped.

**Note:** The Sterling-LWB5 SD Card will need to be powered with a secondary power supply at 1.8V to J3 Pin 2 (VCC\_IO\_EXT) and Pin 16 (GND). 3.3V is for WiFi and 1.8V is for I/O pins. The Sterling-LWB and Sterling-LWB5 SD Cards utilize the same PCBA and because of this the silkscreen will show 3.3V on Jumper J4. Sterling-LWB supports both VIO voltages of 3.3V and 1.8V. Sterling-LWB5 only operates at VIO of 1.8V.

To decide which power supply is best for you, check with the manufacturer of your host development board to determine the maximum current for the power supply used for the SD card slot. If this is too low, consider powering the board externally. See the Sterling-LWB and Sterling-LWB5 module datasheets for power supply requirements of the module in various operating modes.

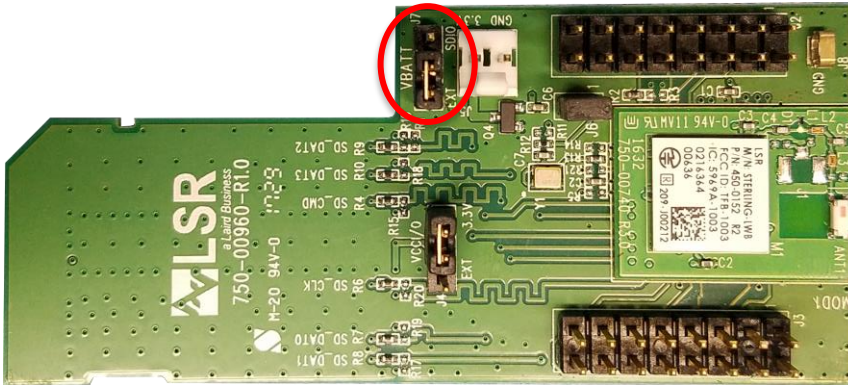

Figure 6: Sterling-LWB SD card board external power connector

## 4 DEVELOPMENT BOARD HOST SOFTWARE CONFIGURATION

The SD card board can be tested on various development boards that have a free SD card slot, a free UART, and two free GPIOs (at a minimum) for basic Wi-Fi and BT operation. The host must also have a PCM audio port available for BT audio.

For detailed information on how to integrate the Sterling-LWB module into an iMX UltraLite development board, refer to the *Integrating Laird Sterling-LWB Wi-Fi and Bluetooth with Freescale i.MX 6 UltraLite Evaluation Kit Under Linux How-to Guide* available from the [Sterling-LWB product page](#). This guide will also work with the Sterling-LWB5 SD Card.



## 5 CONTACTING LAIRD

<b>Headquarters</b>	Laird W66 N220 Commerce Court Cedarburg, WI 53012-2636 USA Tel: 1(262) 375-4400 Fax: 1(262) 375-4248
<b>Website</b>	<a href="https://www.lsr.com/">https://www.lsr.com/</a>
<b>Technical Support</b>	<a href="mailto:cs-support@lairdtech.com">cs-support@lairdtech.com</a>
<b>Sales Contact</b>	<a href="mailto:sales@lsr.com">sales@lsr.com</a>

© Copyright 2017 Laird. All Rights Reserved. Patent pending. Any information furnished by Laird and its agents is believed to be accurate and reliable. All specifications are subject to change without notice. Responsibility for the use and application of Laird materials or products rests with the end user since Laird and its agents cannot be aware of all potential uses. Laird makes no warranties as to non-infringement nor as to the fitness, merchantability, or sustainability of any Laird materials or products for any specific or general uses. Laird, Laird Technologies, Inc., or any of its affiliates or agents shall not be liable for incidental or consequential damages of any kind. All Laird products are sold pursuant to the Laird Terms and Conditions of Sale in effect from time to time, a copy of which will be furnished upon request. When used as a tradename herein, *Laird* means Laird PLC or one or more subsidiaries of Laird PLC. Laird™, Laird Technologies™, corresponding logos, and other marks are trademarks or registered trademarks of Laird. Other marks may be the property of third parties. Nothing herein provides a license under any Laird or any third party intellectual property right.

The information in this document is provided in connection with LS Research (hereafter referred to as “LSR”) products. No license, express or implied, by estoppel or otherwise, to any intellectual property right is granted by this document or in connection with the sale of LSR products. EXCEPT AS SET FORTH IN LSR’S TERMS AND CONDITIONS OF SALE LOCATED ON LSR’S WEB SITE, LSR ASSUMES NO LIABILITY WHATSOEVER AND DISCLAIMS ANY EXPRESS, IMPLIED OR STATUTORY WARRANTY RELATING TO ITS PRODUCTS INCLUDING, BUT NOT LIMITED TO, THE IMPLIED WARRANTY OF MERCHANTABILITY, FITNESS FOR A PARTICULAR PURPOSE, OR NON-INFRINGEMENT. IN NO EVENT SHALL LSR BE LIABLE FOR ANY DIRECT, INDIRECT, CONSEQUENTIAL, PUNITIVE, SPECIAL OR INCIDENTAL DAMAGES (INCLUDING, WITHOUT LIMITATION, DAMAGES FOR LOSS OF PROFITS, BUSINESS INTERRUPTION, OR LOSS OF INFORMATION) ARISING OUT OF THE USE OR INABILITY TO USE THIS DOCUMENT, EVEN IF LSR HAS BEEN ADVISED OF THE POSSIBILITY OF SUCH DAMAGES. LSR makes no representations or warranties with respect to the accuracy or completeness of the contents of this document and reserves the right to make changes to specifications and product descriptions at any time without notice. LSR does not make any commitment to update the information contained herein. Unless specifically provided otherwise, LSR products are not suitable for, and shall not be used in, automotive applications. LSR’s products are not intended, authorized, or warranted for use as components in applications intended to support or sustain life.

# Mouser Electronics

Authorized Distributor

Click to View Pricing, Inventory, Delivery & Lifecycle Information:

[Laird Connectivity:](#)

[450-0171](#) [450-0172](#)